



British Gliding Association

Flight Manual Supplement

Ref BGA 2007/01-02/4351 issue 1

Registration	BGA Number	Manufacturer and type	Serial Number
G-DJAD	BGA 4351	SCHLEICHER ASK21	21659

Title: BGA Operations

Subjects: Extended Weight Operations
Revised Weak Links
Revised Launch speeds
Revised Operational Limitations

Reference: BGA 2007/01 issue 1 (as applicable)
BGA 2007/02 issue 1 (as applicable)
BGA Data Sheets

Applicability: Sailplanes and Self Sustaining Sailplanes issued with a BGA Certificate of Airworthiness prior to 28 September 2008 and transitioned to EASA C of A.

Conditions: The above aircraft, subject to applicability, is approved for operation in accordance with the applicable BGA Data Sheet, as amended.

Any limitation revised or amended by an EASA approved Airworthiness Directive shall have precedence over this flight manual supplement.

Any aircraft operating within the BGA Extended Weight category shall be re-classified as "Utility" - Non Aerobatic, whilst within the extended weight range.

Refer to the BGA Data Sheet for revised limitations.

Approved by the EU commission as a 14(6) derogation dated 4 July 2008, to EC regulation 1592/2002 and 1702/2003 as being compliant with the requirements of Part 21 for continued use on UK registered gliders. Subject to the above applicability and conditions.

Issued by:
British Gliding Association Ltd,
Kimberley House,
Vaughan Way
Leicester
LE1 4SE

10 July 2008

ALEXANDER SCHLEICHER SEGELFLUGZEUGBAU
6416 Poppenhausen/ Wasserkuppe, West Germany

F L I G H T M A N U A L
for the sailplane model

A S K 2 1
=====

This manual must always be carried on board !

It belongs to the sailplane ASK 21

Variant Data Sheet no.339

Serial no.: .. 2 1 6 5 9

Registration no.:

Owner :
.....
.....
.....

Manufacturer : Alexander Schleicher
Segelflugzeugbau
6416 Poppenhausen/ Wasserkuppe
West Germany



This manual is the translation of the German original which is approved by the LBA (Federal Office of Civil Aeronautics of the Fed.Rep. of Germany) as operating instructions according to para 12 (1) 2 of the German 'LuftGerPO' (Aviation Equipment Test Regulations).

The translation has been done by best knowledge and judgement. In any case the original text in German language is authoritative.

APRIL 1980 Edition

ASK 21 Flight Manual

Record of Revisions

Rev. number	Affected Page (s)	Revisions Date	Date Insertion	Ref. / Signature
TN 3	10a	27.10.80	05.11.80	Juw
 TN 4a	Check List / 2, 10c, 10d, 11, 23, 26, 26b, 34	25.11.04	16.12.04	mm
TN 5b	Check List / 2	26.03.81	24.04.81	Juw
TN 6	12	26.03.82	26.04.82	Juw
TN 7	10a	15.12.82	06.01.83	Juw
TN 8	12	16.05.83	20.06.83	Juw
TN 11	Check List / 1, 36a, 36b	20.12.83	18.03.84	Juw
TN 13	10b	16.02.84	28.02.84	Juw
TN 13a	10c	04.06.84	18.06.84	Juw
 ... 15	16a - 19a	25.05.84	12.06.84	Juw
TN 20	Check List 1, 21, 36a, 36b, 37	16.10.87	12.11.87	Juw
TN 21	annex (new tow release coupling)	17.01.90	18.03.90	Juw
TN 22	36b, 37a, 37b	26.11.90	16.12.90	Juw

ASK 21 - Flight Manual

I.1 Amendments Record

No.	Title	PAGE	Date, signature
1	Weak link in towrope (TN no.6)	12	15.04.82 <i>[Signature]</i>
2	Weak link in towrope (TN no.8)	12	16.05.83 <i>[Signature]</i>
3	Automatic elevator connection (TN no. 11)	36a, 36b Check- list/1	20.12.83 <i>[Signature]</i>
4	Modification of the flight manual (TN no. 13)	10 b	23.02.84 <i>[Signature]</i>
5	Amendment to the Flight Manual (TN no. 13 a)	10 c	June 84 <i>[Signature]</i>
6	New canopy locking system (TN no. 15)	16a 17a 18a 19a	19.08.84 <i>[Signature]</i>
7	Change/supplement to the Flight Manual (TN No. 20)	Check- list/1 21, 36a, 36b, 37	03.11.87 <i>[Signature]</i>
8	TM Nr. 21, new production series tow release couplings for aerotow and winch launch	annex	17.08.90 <i>[Signature]</i>
9	Checking and exchange of the parallel rocker at the elevator actuator rod, TN No. 22	36b, 37a, 37b	26.11.90 <i>[Signature]</i>
10	Revision of the Flight Manual TN No. 23	13, 15, 25, 26	15.04.91 <i>[Signature]</i>

Check List / 1

=====

Pre Flight Check

1. Main pins safetied ?
2. Rear wing attachment pins: is the safety lock visible above the pin ?
3. Horizontal tail unit pins safetied ? Is the spring retainer engaged ?
4. Elevator pushrod connected ?
Safetied with a spring clip ?
This is not applicable for gliders which use the automatic elevator connection !
5. Aileron pushrods connected ?
Safetied with a spring clip ?
Do not forget the sight control through the access hole cover !
6. Airbrake pushrods connected ?
Safetied with a spring clip ?
Do not forget the sight control through the access hole cover !
7. Check for foreign bodies !

Attention !

With all HOTELLIER quick-release joints one must be able to touch the ball pivot by feeling through the slot in the ball socket. Check the proper engagement of the safety lock by pushing it on to close !

C H E C K L I S T / 2
=====

Pre take off check

1. Parachute connected to harness ?
2. Safety harness fastened ?
3. Airbrakes locked ?
4. Trim lever adjusted to a middle position ?
5. Altimeter adjusted ?
6. Canopies closed and locked ?
Rear canopy !!
7. For flight with only one occupant remove
rear back rest !!
8. Put your toes under the toe-straps !!
Do not flatten the straps !!
Danger of jamming the pedals !!

ASK 21 Flight Manual

Check List / 2

Pre take-off check:

1. Tail dolly removed – ballast checked?
2. Parachute properly fastened – raise line?
3. Safety harness properly fastened – all operating elements within reach?
4. Put your toes under the toe-straps! Do not flatten the straps!
Danger of jamming the pedals!
5. Airbrakes retracted and locked?
6. Placard for spin ballast?
7. Altimeter adjusted?
8. Radio on – frequency and volume checked?
9. Trim adjusted?
10. Control circuit check – Controls easy to operate?
11. Airspace for start and release clear?
12. Check wind
13. Prepared for take-off interruption?
14. Both canopies closed and locked? – Emergency jettisoning procedure in mind?

Rev.Nr. / Date Sig.
TM 4a Nov. 04 JN/MG

Author
Kaiser

Date
April 80

LBA-appr.

ASK 21 - Flight Manual

V.2	Derigging	37
V.3	Parking	37
V.4	Road Transport	37
V.5	Preventive maintenance	38
	Airspeed position error	39
	Speed polar	40
	Lubrication scheme	41

I.3 DESCRIPTION

The ASK 21 is a two-seater sailplane with T-tail, fixed nose wheel and dive brakes on upper wing. The main landing gear is sprung.

The sailplane is built in FRP-sandwich-monocoque construction. It may be used for school and high performance flights as well as for aerobatics of the Airworthiness Category 'A'.

Technical Data

Span	17.00 m	(55,74 ft)
Length	8,35 m	(27,38 ft)
Height	1,55 m	(5,08 ft)
Wing area	17,95 m ²	(192,95 sq.ft)
Aspect ratio	16,1	
Max all-up weight	600 kg	(1320 lbs)
Max wing loading	33,4kg/M ²	(6,84 lbs/sq.ft)

II. OPERATING LIMITATIONS

II.1 AIRWORTHINESS CATEGORY

Basis of the type-approval are the Airworthiness Requirements for Sailplanes and Powered Sailplanes (LFSM), issue Oct. 23, 1975, with the Airworthiness Category 'A' (Acrobatic).

II.2 OPERATION RANGE CLASSES

The operation range classes approved for the particular sailplane are indicated by a data placard on the instrument panel (see Maintenance Manual page). Depending on the respective equipment the sailplane may be licensed for traffic for the following operation range classes :

1. Airworthiness Category 'U' (UTILITY)
 - a. According to VFR (during daylight) - with equipment as per II.3 a.
 - b. Cloud flights - with equipment as per II.3 a and II.3 c.

2. Airworthiness Category 'A' (Acrobatic)
 - with equipment as per II.3 a and II.3 b or II.3 a, II.3 b and II.3 c - for the following aerobatics :
 - Loop, Stall Turn, Split 'S', Immelmann, Slow Roll, Inverted Flights, Spin, Steep Climbing Turn, Lazy Eight, Chandelle.

II.3 EQUIPMENT

a. Min. equipment

1. Airspeed indicator up to 300 km/h
2. Altimeter
3. Four-piece safety harness for front and rear seat
4. Seat cushions, at least 10cm thick when loaded, or parachutes (automatic or manual)
5. Weight and balance data placard (front and rear seat)
6. Data plate
7. Flight Manual

b. Equipment for aerobatics

For aerobatics the above min. equipment must be supplemented as follows :

1. Additional bottom strap for the safety harness
2. G-meter for front seat
3. Foot loops on rudder pedals
4. Parachute (automatic or manual)

c. Equipment for cloud flying

For cloud flying the above min. equipment must be supplemented as follows :

1. Variometer
2. Turn and bank indicator
3. Magnetic compass (compensated)
4. VHF transceiver radio

II.4 SPEEDS

Max speed calm air	$V_{NE} = ^*)280$ km/h	(151 kts)
Max speed rough air	$V_B =$	200 km/h (108 kts)
Max maneuvering speed	$V_M =$	180 km/h (97 kts)
Max speed aerotow	$V_T =$	180 km/h (97 kts)
Max speed winch tow	$V_W =$	150 km/h (81 kts)

Rough air means turbulence found in wave-rotors, Cn-clouds, dust devils or when skimming mountain crests.

Maneuvering speed V_M is the highest speed at which full control deflections still may be applied.

With max speed V_{NE} only one third of the max possible deflections may be applied. One must also take into account that with increasing altitude the true airspeed is higher than the reading of the A.S.I. because of the decreasing air density.

True airspeed (TAS) is, however, relevant for safety against flutter.

*) The max indicated V_{NE} is reduced as follows according to altitude :

Altitude (M)	0-2000	3000	4000	5000	6000
V_{NE} indicated (km/h)	280	267	255	239	226

Altitude (ft)	5000	10000	15000	20000
V_{NE} indicated (kts)	151	144	132	121

The airspeed indicator must show the following color codes :

Green arc	80-180 km/h	(43- 97 kts)
Yellow arc	180-280 km/h	(97-151 kts)
Red radial line	at 280 km/h	(at 151 kts)
Yellow triangle	at 90 km/h	(at 48,5 kts)

II.5 LOAD FACTORS

The following load factors must not be exceeded :

at maneuvering speed V_M	+6,5	-4,0
at max speed V_{NE}	+5,3	-3,0
with airbrakes extended	+3,5	± 0

G-meter markings :

- a. positive range
 - yellow arc +5,3 to +6,5
 - red radial line at +6,5
- b. negative range
 - yellow arc -3,0 to -4,0
 - red radial line at -4,0

II.6 WEIGHTS

Empty weight	approx. 360kg	(792 lbs)
Max all-up weight	600kg	(1320 lbs)
Max weight of non lift producing members	410kg	(904 lbs)

II.7 IN FLIGHT C.G.

The in flight c.g. range is from 234mm to 469mm behind datum (9,21" to 18,46"); correspondingly 20,2 % up to 41,1 % of the mean aerodynamic chord,

$t_m = 1,121m$ (3'68") with $a = 8mm$ (0,32") behind wing leading edge; inner wing = datum point.

II.8 WEIGHT AND BALANCE INFORMATION

Min payload front seat	70kg	(154 lbs)
Max payload front seat	110kg	(242 lbs)
Max payload rear seat	110kg	(242 lbs)
Baggage in wingroots max	2 x 10kg	(2 x 22 lbs)

Neither the all up weight of 600kg (1320 lbs) nor the max weight of non-lift producing members + occupants & baggage of 410kg (904 lbs) must be exceeded.

The weight limitations on the basis of the last weighing are to be found on page 11 !

With this loading the in flight c.g. is in the permissible range.

Low weight in the front seat must be compensated by fixed ballast.

ASK 21 Flight Manual

Towards II 8. Weight and balance information with spin ballast

With every new weighing of the sailplane; a current spin ballast-table must be requested from the manufacturer and filed after this page.

Before every flight with spin ballast the pilots must be weighed with the equipment worn in flight (clothes, parachute ...). The amount of spin ballast is specified in the current spin ballast-table. The mass of the pilot in the front seat defines the line of the table; the mass of the pilot in the rear seat defines the column of the table. At the intersection, the number of ballast plates (1 kg = 2.2 lbs), which are to be attached, is noted.

Other cockpit ballast must be removed. The use of this table ensures a permissible in-flight C. of G.-position, even if the cockpit load falls below the minimum cockpit load specified in the Weight and Balance Form.

Up to a maximum of 12 spin ballast plates are permissible. The plates have to be distributed evenly to the left and right side of the fin and have to be fixed with the provided screw.

CAUTION: *The washer and nut fixed at the cockpit placard (see below) must be used. After removal of the spin ballast the washer and the nut must be fixed again on the placard.*

Attention



Check spin ballast!

Only use spin ballast for flights
with two pilots!

Rev.Nr. / Date Sig.
TM 4a Nov. 04 JN/MG

Author
Kaiser

Date
April 80

Seite 10c

LBA-appr.

ASK 21 Flight Manual

This table gives the number of weights to be mounted at the tail for spin training (section IV.6)

Serial No: 21659
 Registration: G-DJAD
 Date: 21.09.10

Empty mass: 841 lbs
 Empty mass Centre of Gravity: 29.4 inch
 Weight and Balance report dated: 08.09.10

Max. permissible payload: 482 lbs
 Equipment list dated: 08.09.10

	pilot mass incl. parachute in rear seat (lbs)																				
	154	159	163	168	172	176	181	185	190	194	198	203	207	212	216	220	225	229	234	238	243
141	2	2	2	2	3	3	3	3	3	4	4	4	4	4	4	5	5	5	5	5	5
146	2	2	3	3	3	3	4	4	4	4	4	5	5	5	5	5	5	6	6	6	6
150	3	3	3	3	4	4	4	4	5	5	5	5	5	5	6	6	6	6	6	7	7
154	4	4	4	4	4	5	5	5	5	5	6	6	6	6	6	6	7	7	7	7	7
159	4	4	5	5	5	5	5	6	6	6	6	7	7	7	7	7	7	8	8	8	8
163	5	5	5	5	6	6	6	6	7	7	7	7	7	7	8	8	8	8	8	9	9
168	5	6	6	6	6	6	7	7	7	7	8	8	8	8	8	8	9	9	9	9	9
172	6	6	7	7	7	7	7	8	8	8	8	8	9	9	9	9	9	10	10	10	10
176	7	7	7	7	8	8	8	8	8	9	9	9	9	9	10	10	10	10	10	10	11
181	7	8	8	8	8	8	9	9	9	9	10	10	10	10	10	11	11	11	11	11	11
185	8	8	9	9	9	9	9	10	10	10	10	11	11	11	11	11	11	11	12	12	12
190	9	9	9	10	10	10	10	10	11	11	11	11	11	11	12	12	12	12	12	12	12
194	9	10	10	10	10	10	11	11	11	11	12	12	12	12	12	12	12	12	12	12	12
198	10	10	11	11	11	11	11	12	12	12	12	12	12	12	12	12	12	12	12	12	12
203	11	11	11	11	12	12	12	12	12	12	12	12	12	12	12	12	12	12	12	12	12
207	11	12	12	12	12	12	12	12	12	12	12	12	12	12	12	12	12	12	12	12	12
212	12	12	12	12	12	12	12	12	12	12	12	12	12	12	12	12	12	12	12	12	12
216	12	12	12	12	12	12	12	12	12	12	12	12	12	12	12	12	12	12	12	12	12
220	12	12	12	12	12	12	12	12	12	12	12	12	12	12	12	12	12	12	12	12	12
225	12	12	12	12	12	12	12	12	12	12	12	12	12	12	12	12	12	12	12	12	12
229	12	12	12	12	12	12	12	12	12	12	12	12	12	12	12	12	12	12	12	12	12
234	12	12	12	12	12	12	12	12	12	12	12	12	12	12	12	12	12	12	12	12	12
238	12	12	12	12	12	12	12	12	12	12	12	12	12	12	12	12	12	12	12	12	12
243	12	12	12	12	12	12	12	12	12	12	12	12	12	12	12	12	12	12	12	12	12

pilot mass incl. parachute in front seat (lbs)

= invalid loading

Note: This table becomes invalid when the aircraft is modified or with the date of: 08.9.2014

Mod. No TN 4a

Date Nov. 04
 Sig. JN/MG

drawn up by: *M Ca.*

Page 10d
 LBA-appr.

ASK 21 Flight Manual

This table gives the number of weights to be mounted at the tail for spin training (section IV.6)

Serial No: 21859 Empty mass: 381 kg Max. permissible payload: 219 kg
 Registration: G-DJAD Empty mass Centre of Gravity: 748 mm
 Date: 21.09.10 Weight and Balance report dated: 08.08.10 Equipment list dated: 08.09.10

		pilot mass incl. parachute in rear seat (kg)																				
		70	72	74	76	78	80	82	84	86	88	90	92	94	96	98	100	102	104	106	108	110
pilot mass incl. parachute in front seat (kg)	64	2	2	2	2	2	3	3	3	3	3	4	4	4	4	4	5	5	5	5	5	5
	66	2	2	3	3	3	3	4	4	4	4	4	4	5	5	5	5	5	6	6	6	6
	68	3	3	3	3	4	4	4	4	4	4	5	5	5	5	6	6	6	6	6	6	7
	70	4	4	4	4	4	5	5	5	5	5	5	6	6	6	6	6	7	7	7	7	7
	72	4	4	5	5	5	5	6	6	6	6	6	6	7	7	7	7	7	8	8	8	8
	74	5	5	5	5	6	6	6	6	7	7	7	7	7	7	8	8	8	8	8	8	9
	76	5	6	6	6	6	6	7	7	7	7	7	8	8	8	8	8	9	9	9	9	9
	78	6	6	7	7	7	7	7	8	8	8	8	8	9	9	9	9	9	10	10	10	10
	80	7	7	7	7	8	8	8	8	8	8	9	9	9	9	9	10	10	10	10	10	11
	82	7	8	8	8	8	8	8	9	9	9	9	10	10	10	10	10	10	11	11	11	11
	84	8	8	9	9	9	9	9	10	10	10	10	10	10	11	11	11	11	11	11	12	12
86	9	9	9	9	10	10	10	10	10	11	11	11	11	11	11	12	12	12	12	12	12	
88	9	10	10	10	10	10	11	11	11	11	11	11	12	12	12	12	12	12	12	12	12	
90	10	10	11	11	11	11	11	11	12	12	12	12	12	12	12	12	12	12	12	12	12	
92	11	11	11	11	12	12	12	12	12	12	12	12	12	12	12	12	12	12	12	12	12	
94	11	12	12	12	12	12	12	12	12	12	12	12	12	12	12	12	12	12	12	12	12	
96	12	12	12	12	12	12	12	12	12	12	12	12	12	12	12	12	12	12	12	12	12	
98	12	12	12	12	12	12	12	12	12	12	12	12	12	12	12	12	12	12	12	12	12	
100	12	12	12	12	12	12	12	12	12	12	12	12	12	12	12	12	12	12	12	12	12	
102	12	12	12	12	12	12	12	12	12	12	12	12	12	12	12	12	12	12	12	12	12	
104	12	12	12	12	12	12	12	12	12	12	12	12	12	12	12	12	12	12	12	12	12	
106	12	12	12	12	12	12	12	12	12	12	12	12	12	12	12	12	12	12	12	12	12	
108	12	12	12	12	12	12	12	12	12	12	12	12	12	12	12	12	12	12	12	12	12	
110	12	12	12	12	12	12	12	12	12	12	12	12	12	12	12	12	12	12	12	12	12	

= invalid loading

Note: This table becomes invalid when the aircraft is modified or with the date of: 08.9.2014

Date of weight & balance	Empty weight c.g. (mm/in. behind datum)	Front seat kg/lbs payload incl. chute min max	Rear seat kg/lbs payload incl. chute min max	Old spin ballast table removed (check off)	Signature of inspector, inspection stamp
8/9/10	E.W 381 kg E.C.F 747mm	64kg 110kg	N/A 110kg		O. Taylor 11A174 <i>[Signature]</i> NYS.

* Flight Manual Page 10d

Rev./Date
TM 4a Nov. 04
Sig. JN/MG

Author
Kaiser
Date
April 80

Seite 11
LBA-appr.

ASK 21 Flight Manual

Date of weight & balance	Empty weight c.g. (mm/in. behind datum)	Front seat kg/lbs payload incl. chute min max	Rear seat kg/lbs payload incl. chute min max	Old spin ballast table removed (check off)	Signature of inspector, inspection stamp
8/9/10	E.W 381 kg E.C.F 767 mm	64 kg 110 kg	N/A 110 kg		O. Taylor 11A174 <i>[Signature]</i> NYS.

* Flight Manual Page 10d

Rev. N. / Date
TM 4a Nov. 04
Sig. JN/MG

Author
Kaiser
Date
April 80

Seite 11
LBA-Appr.

II.9 TOW RELEASES

For aerotow : nose release E 75

For winch tow : safety release Europa G 73

II.10 WEAK LINK IN TOW ROPE

Aerotow max. 600 \pm 60 daN

Winch tow max. 1000 \pm 100 daN

II.11 TIRE PRESSURE

Main wheel 5.00-5 : 2,7 bar

Nose wheel 4.00-4 : 2,0 bar

Tail wheel 210x65 2,5 bar

II.12 CROSSWIND

The permissible crosswind component is about 15 km/h.
(8 knots).

ASK 21 Flight Manual

III. EMERGENCY PROCEDURES

III.1 RECOVERY FROM SPIN

According to the standard procedure spinning is terminated as follows:

1. Apply opposite rudder (i.e. apply rudder against the direction of rotation of the spin).
2. Short pause (hold control inputs for about 1/2 spin turn).

Warning: Disregarding the pause will result in slower recovery!

3. Release stick (i.e. give in to the pressure of the stick) until the rotation stops and sound airflow is established again.

Warning: Full forward stick may retard or even prevent the recovery!

4. Centralise rudder and allow sailplane to dive out.
The altitude loss from the beginning of the recovery until the normal flight attitude is regained is about 80 meter (260 feet).

Note: During spins the ASK 21 oscillates in pitch. From a steep nose down spin recovery according to the standard procedure is up to 1 turn, from a flat spin less than 1 turn.

III.2 CANOPY JETTISONING AND EMERGENCY BAIL OUT

- Front canopy:
- a. Move lever with red knob above the instrument panel to the left and push canopy upwards.
 - b. Open safety harness.
 - c. Get up and bail out.
 - d. With manual chute seize release grip and pull out entirely after 1 to 3 seconds.

Rev.no./Date Sig.
TN23 Jan.91 Waibel

Author Date
Kaiser April 80

Page no.
LBA- 13
APP.

- Rear canopy :
- a. Pull back both canopy side locks and push canopy upwards.
 - b. Open safety harness.
 - c. Get up and bail out.
 - d. With manual chute seize release grip and pull out entirely after 1-3 seconds.

If circumstances allow, the front pilot should allow the rear pilot to bail out first.

III.3 FLIGHTS IN THE RAIN

With wet or slightly iced wings or insect accumulation there will be no deterioration in flight characteristics.

However, one has to reckon with a rather considerable deterioration in flight performance. This must be taken into account especially on landing final approach !!

Add a safety margin of 10 km/h (5.4 knots) for approach speed !!

ASK 21 Flight Manual

III.4 WING DROPPING

The sailplane stalls extremely benign. Nevertheless one always has to face the possibility of wing dropping because of turbulence. In that case push stick forward immediately and apply opposite rudder against a noticeable turn at the same time to regain a normal flight attitude. If the rudder deflection against the turn is forgotten, a spin may occur even if the stick pressure is released.

III.5 GROUND LOOPING

For normal conditions, smooth runway, short grass, one may take off with the wing on the ground without having to fear a change in the direction.

High grass and rough ground, however, may cause ground looping. In that case release the tow rope immediately.

Rev. no. / Date Sig.
TN23 Jan. 91 Waibel

Author Date
Kaiser April 80

Page no.
LBA- 15
APP.

ASK 21 Flight Manual

III.4 WING DROPPING

The sailplane stalls extremely benign. Nevertheless one always has to face the possibility of wing dropping because of turbulence. In that case push stick forward immediately and apply opposite rudder against a noticeable turn at the same time to regain a normal flight attitude. If the rudder deflection against the turn is forgotten, a spin may occur even if the stick pressure is released.

III.5 GROUND LOOPING

For normal conditions, smooth runway, short grass, one may take off with the wing on the ground without having to fear a change in the direction.

High grass and rough ground, however, may cause ground looping. In that case release the tow rope immediately.

Rev.no./Date Sig.
TN23 Jan.91 Waibel

Author Date
Kaiser April 80

Page no.
LBA- 15
APP.

IV. NORMAL OPERATING PROCEDURES

IV.1. COCKPIT LAYOUT AND CONTROLS

Front seat:

No.1: Stick.

No.2: Trim; flat lever with green knob
LH of stick.

No.3: Rudder pedal adjustment; grey knob
at the console.

No.4: Airbrakes with wheelbrake; blue le-
ver in the left arm rest.

No.5: Release cable; yellow knob on left
cockpit wall below the canopy frame.

No.6: Canopy emergency jettisoning; hori-
zontal lever with red flat grip above
the instrument panel cover; to the
left = OPEN.

No.7: Front canopy locking:
White swivel levers on left and right
canopy frame.
To open canopy: pull back both levers.
To lock canopy: push both levers for-
wards, parallel to the
canopy frame.

No.8: Ventilation nozzle; on right cockpit
wall below the canopy frame; revol-
ving and lockable.

No.9: Back rest; the back rest is adjust-
able by tilting it from the bottom up-
wards and forwards (see sketch); in
normal flight attitudes the back rest
cannot shift by itself.
Very tall pilots may fly without the
back rest.

No.10: Trim indicator; in the right arm
rest behind the ventilation nozzle.

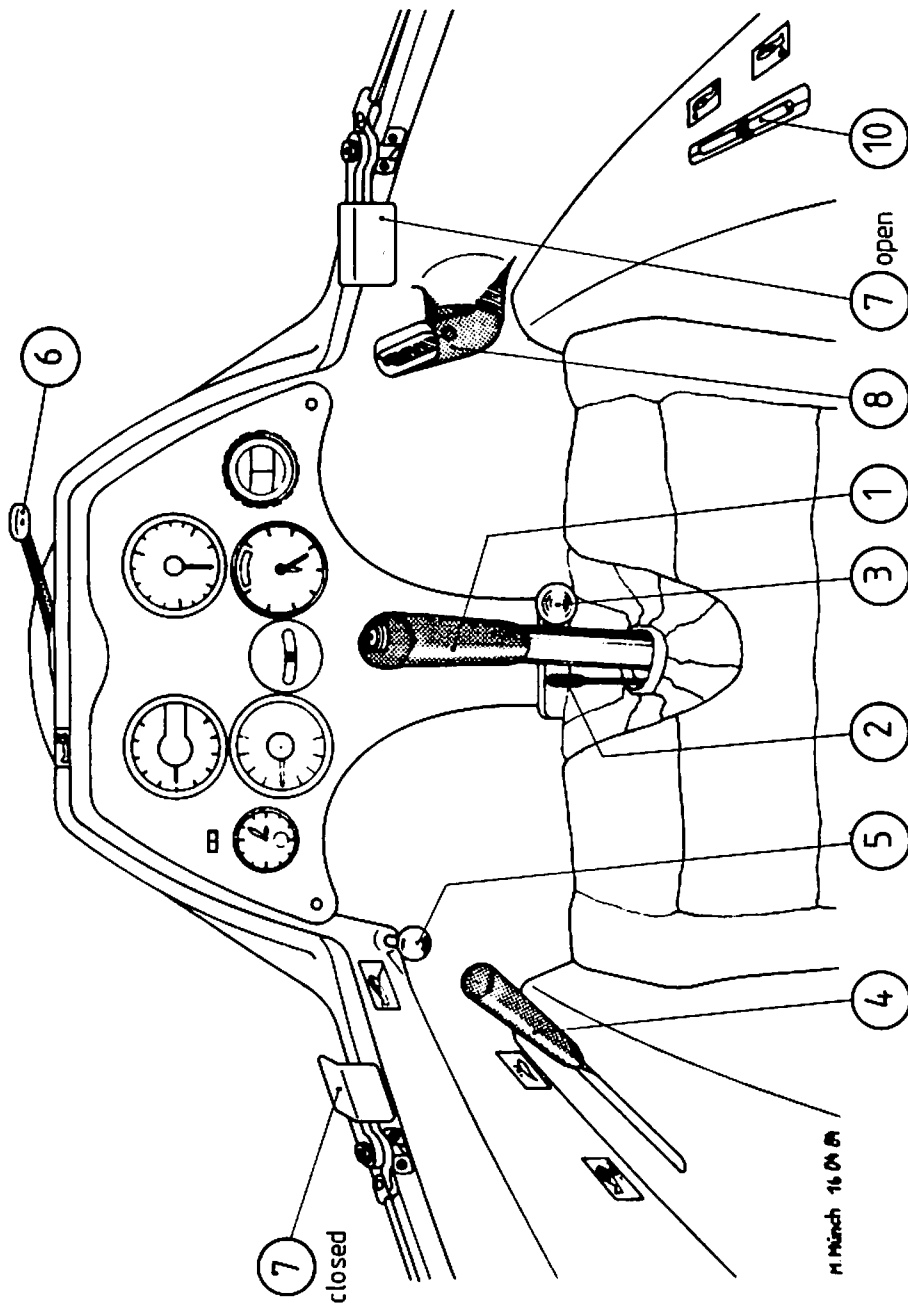

11 March 16 09 81

Rear seat:

- No.1: Stick.
- No.2: Trim; flat lever with green knob LH of stick.
- No.3: Rudder pedal adjustment with circular grip in front of stick.
- No.4: Airbrakes with wheelbrake; blue lever in the left arm rest.
- No.5: Release cable; yellow knob on left cockpit wall below the canopy frame.
- No.6: Rear canopy locking = Canopy emergency jettisoning; red swivel levers on left and right canopy frame.
To open canopy: pull back both levers.
To lock canopy: push both levers forwards, parallel to the canopy frame.
- No.7: Ventilation nozzle; on right cockpit wall below the canopy frame; revolving and lockable.
- No.8: Back rest; the back rest is adjustable by tilting it from the bottom upwards and forwards (see sketch); in normal flight attitudes the back rest cannot shift by itself.
Very tall pilots may fly without the back rest.
- No.9: Trim indicator; in the right arm rest behind the ventilation nozzle.

ASK 21 Flight Manual

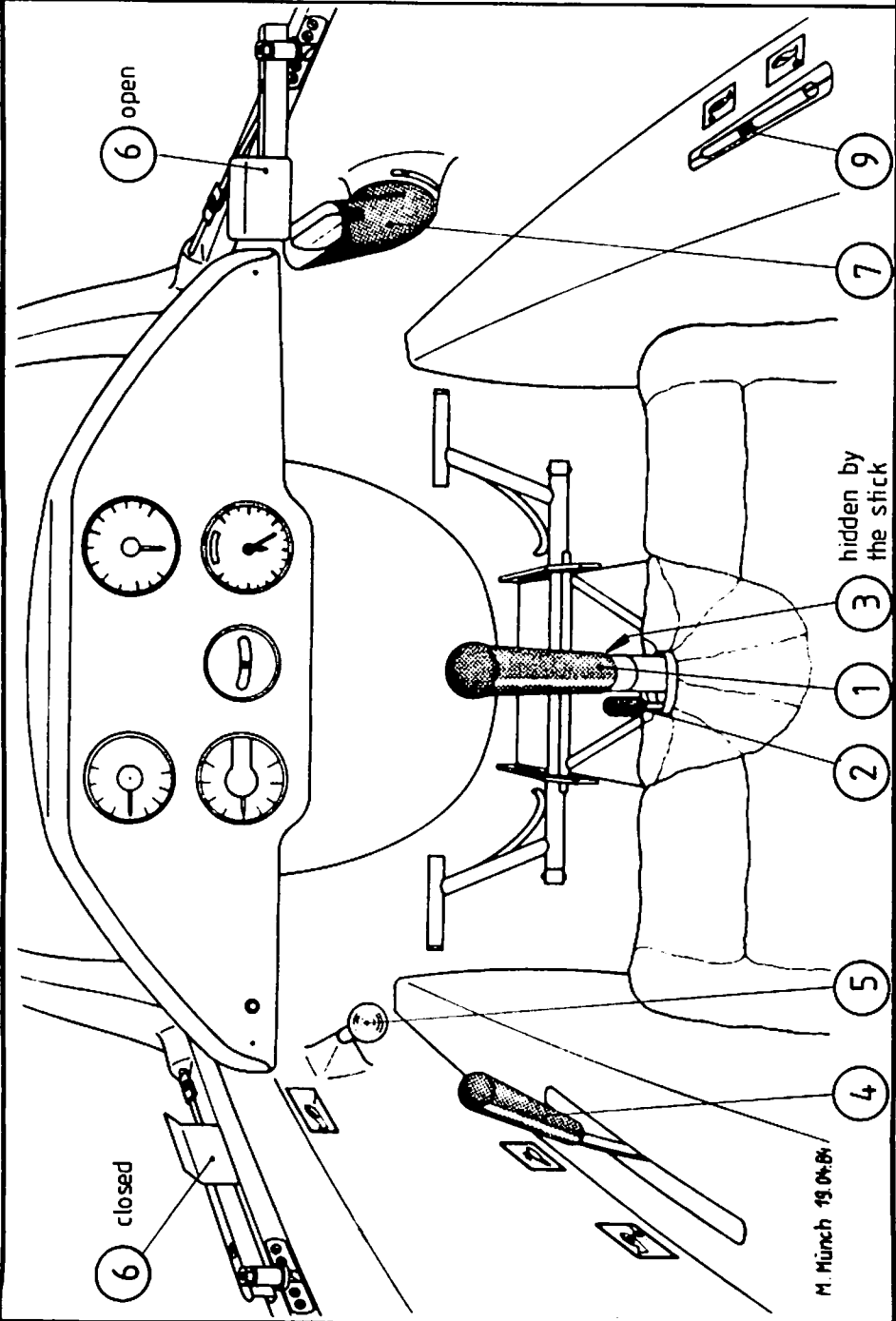

hidden by the stick

M. Münch 19.04.84

BACK REST ADJUSTMENT

Adjustment

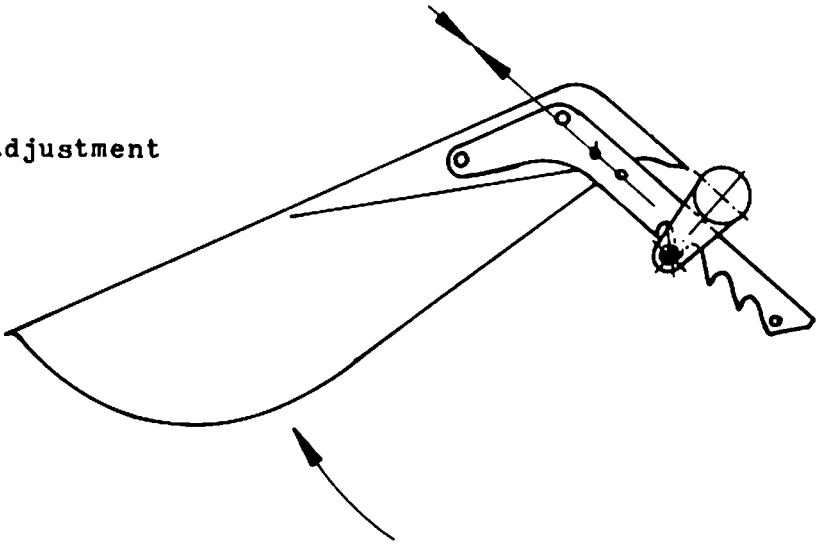

Engaged

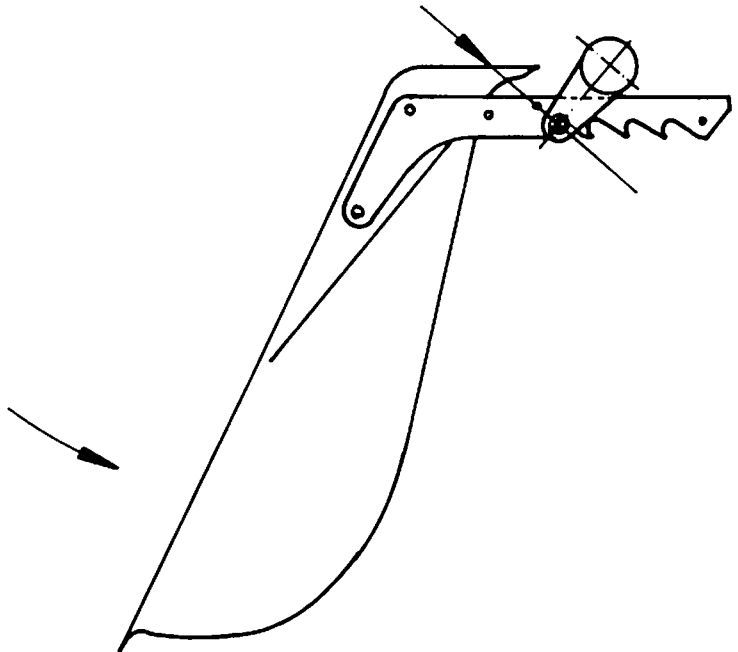

IV.2 Daily Inspections

- 1.a) Open canopy! Check that the main pins are properly secured.
 - b) Check the proper connection of the ailerons and airbrakes through the access hole on the left side above the wing. Are the quick-release connectors secured with spring clips ?
 - c) Check for foreign bodies !
 - d) Check the control circuits force and that all controls are free-moving. Apply full deflections and load the control circuits with fixed controls and airbrakes.
Check the plastic tubes inside the S-shaped tubes of the rudder pedals for proper and tight fit.
 - e) Check tire pressure:
Nose wheel 2,0 bar (28 psi)
Main wheel 2,7 bar (38 psi)
Tail wheel (If installed) 2,5 bar (35,6 psi).
 - f) The condition and function of the tow release mechanism is to be checked. Actuate the tow release: does it snap back freely ? Engage and disengage the ring pair. Check the automatic release of the C.G. towing hook with the ring pair which must release automatically backwards.
 - g) Check the wheel brake. Pull the airbrake lever; at the end of its travel an elastic resistance must be felt.
- 2.a) Check upper and lower wing surface for damages !
 - b) Aileron: its condition, free-movingness and play is to be checked ! Check also the pushrod connection.
 - c) Airbrake: its condition, fit and locking is to be checked.
- 3.) Check the fuselage for damages, in particular also the bottom side.
 - 4.) Check that the tailplane is properly assembled and secured. Check also the pushrod connection. Secured by spring clips ?

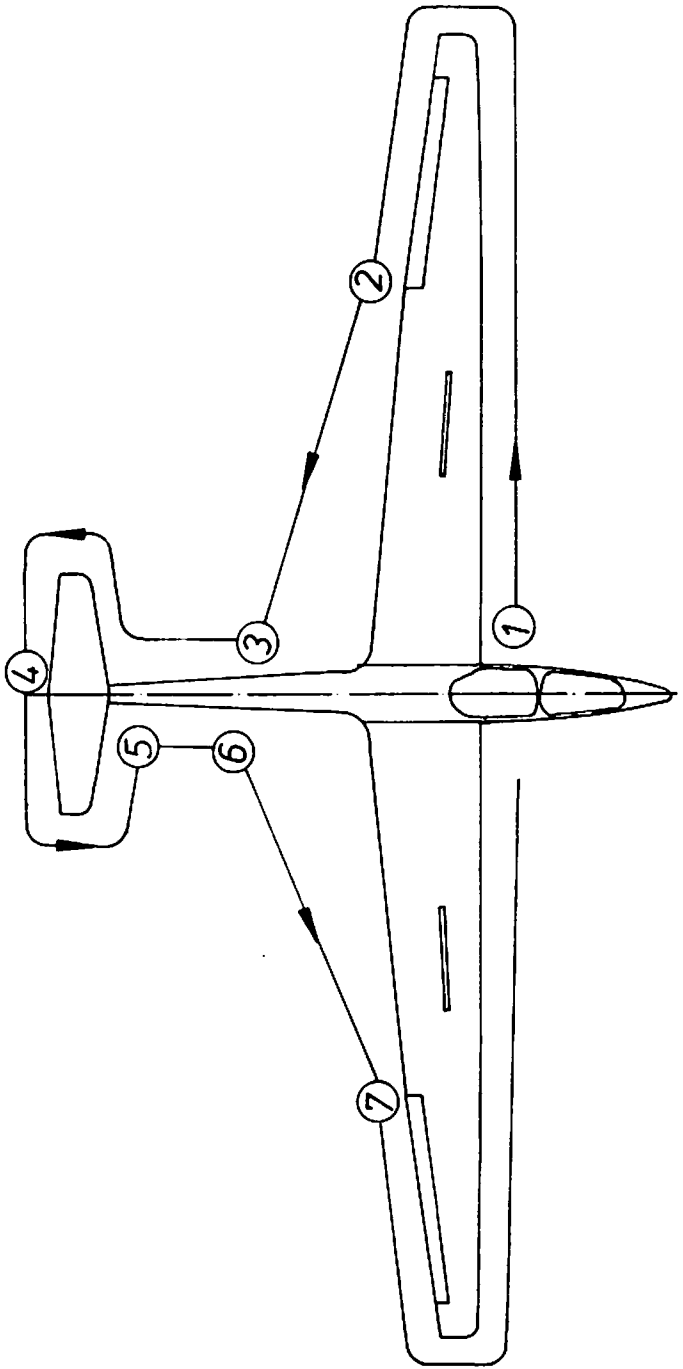

DAILY CHECKS (see IV.2)

5. Check condition of tailskid, pitot tube and venturi tube !
6. Check static vents for cleanness !
7. See 2.

After rough landings or excessive flight stress the whole sailplane must be checked with the wings and tail unit removed. If any damage is found, a technical inspector must be called in. On no account one must take off again before the damage has been repaired.

See also Maintenance Manual !!

IV.3 PRE TAKE OFF CHECK

1. Controls easy to operate ?? (Control circuits check done ??)
2. Airbrakes locked ??
3. Trim neutral ??
4. Canopy locked ?? Pay especially attention to the rear canopy !
5. Safety harness and parachute fastened ?? (Parachute static line engaged with automatic parachute ??)
6. Altimeter adjusted to field height or to zero ??
7. Radio "on" and adjusted to proper frequency ??

- 5) Check condition of tailskid, pitot tube and venturi tube!
- 6) Check static vents for cleanness!
- 7) See 2.)

After rough landings or excessive flight stress the whole sailplane must be checked with the wings and tail unit removed. If any damage is found, a technical inspector must be called in. On no account one must take off again before the damage has been repaired.

See also Maintenance Manual.

IV.3 Pre take-off check

1. Tail dolly removed – ballast checked?
2. Parachute properly fastened – raise line?
3. Safety harness properly fastened – all operating elements within reach?
4. Put your toes under the toe-straps! Do not flatten the straps!
Danger of jamming the pedals!
5. Airbrakes retracted and locked?
6. Placard for spin ballast?
7. Altimeter adjusted?
8. Radio on - Frequency and volume checked?
9. Trim adjusted?
10. Control circuit check – Controls easy to operate?
11. Airspace for start and release clear?
12. Check wind
13. Prepared for take-off interruption?
14. Both canopies closed and locked –
Emergency jettisoning procedure in mind?

IV.4 TAKE OFF

Winch tow :

Trim neutral.

Max tow speed : 150 km/h (81 kts).

The sailplane features a tow release for winch tow in front of the main wheel.

The most favorable tow speed is 90 - 110 km/h (49 - 60 kts).

There is little pitch up tendency during the initial tow. In the upper third of the tow additional altitude may be gained by slight back pressure.

Tow release : pull the release knob to the stop several times.

Aero tow :

Aero tows only with the nose release in front of the nose wheel.

Recommended tow rope length : 30-60 m (98-197 ft); textile rope.

Trim neutral.

Max tow speed : 180 km/h (97 kts).

The most favorable tow speed during climb is 90 - 140 km/h (49 - 76 kts).

Take off may be done with the wingtip on the ground. Getting the wings level is no problem. However, the pilot is advised to be careful with high grass and very rough ground.

Take off takes place at about 75 km/h (40 kts).

ASK 21 Flight Manual

IV.5 FREE FLIGHT

The sailplane may be flown up to $V_{NE} = 280$ km/h (151 kts), see p.8. Up to manoeuvring speed of 180 km/h (97 kts) full control deflections can be applied. At higher speeds the controls must be applied more carefully.

At V_{NE} only 1/3 of the max. possible deflections must be applied.

IV.6 LOW SPEED FLIGHT, WING DROPPING AND SPINS

With the stick back a distinct tail buffet is felt.

The sailplane is very benign in low speed flight. By use of normal aileron deflections the wings may be kept level down to minimum speed, even with aft C.ofG.-positions.

With normal rudder deflections no wing dropping is found. Yaw angles of up to 5° have no significant influence on the wing dropping attitude.

Also rapid pulling up into 30° pitch does not cause wing dropping, but only a gentle nose drop. The same applies for stalling out of a 45° turn.

But one has to point out that even the most benign sailplane needs speed in order to be controllable.

In turbulence this is especially important when also a wing dropping may occur.

Spin development from wing dropping strongly depends on the C.ofG. position and also to some extent from the pilot reaction.

For C.ofG.positions forward of 315 mm aft of datum the ASK 21 does not spin at all. This configuration applies to 2 heavy pilots.

For C.ofG.-positions from 320 mm through 385 mm aft of datum, more incipient spin turns are possible followed by self recovery after 4 1/2 turns at most. Such C.ofG.-positions are possible in dual flight with a lightweight pilot in the front seat.

For C.ofG.-positions aft of 400 mm behind datum controllable sustained spins are possible. Such a C.ofG.-position is usually only possible with one lightweight pilot in the front seat.

Rev. no. / Date Sig.
TN23 Jan. 91 Waibel

Author Date
Kaiser April 80

Page no.
LBA- 25
APP.

ASK 21 Flight Manual

For C. of G.-positions aft of 400 mm behind datum controllable sustained spins are possible. Such a C. of G.-position is usually only possible with one lightweight pilot in the front seat.

Note: During spins the ASK 21 oscillates in pitch. From a steep nose down spin recovery according to the standard procedure is up to 1 turn, from a flat spin less than 1 turn.

The speed at which the stall takes place depends on the payload. The following standard values are applicable:

	without AB	with AB
Single, all up weight 470kg	65 km/h IAS (35 kts)	68 km/h IAS (37 kts)
Dual, all up weight 600 kg	74 km/h IAS (40 kts)	77 km/h IAS (42 kts)

Spinning with spin ballast

Mounting of spin ballast see chapter II.8 Mass and Balance Form. Spinning with spin ballast is principally only allowed by dual flights. With spin ballast other aerobatic manoeuvres are not permissible.

Entry procedure:

The best entry speed is 2 km/h (1.1 kts) above the speed, at which the stall warning sets in. This must be checked before in flight.

Step hard on the rudder in the intended spin direction. Then, fully pull the stick. The aileron stays neutral. The rudder must stay in this position as long as the spin is supposed to continue.

WARNING: *If a spiral dive sets in, it must be stopped immediately, to prevent overstressing the structure.*

Recovery procedure:

Recovery according to the standard procedure, see chapter III.1.

ASK 21 Flight Manual

IV.7 High Speed Flight

The sailplane shows no flutter tendency within the permissible speed range.

With airbrakes extended in a 45° dive the speed remains below $V_{NE} = 280$ km/h (151 kts); it goes up to 232 km/h (125 kts) at $G = 600$ kg (1323 lbs).

IV.8 Cloud flying

For min. equipment for cloud flying see II.3 a & II.3 c.

According to past experiences the airspeed indicator system is not exposed to the danger of icing-up. However with strong icing-up the pilot must be always take into account the possible failure of the airspeed indicator. When planning cloud flying, he must take this point into consideration.

Excessive speeds during cloud flying must be avoided in any case. The pilot should try to keep an average speed of about 100 km/h (54 kts) and with increasing speed above 130 km/h (70 kts) he should use the airbrakes in order to control the speed.

Rev.Nr. / Date Sig.
TM 4a Nov. 04 JN/MG

Author
Kaiser

Date
April 80

Seite 26b

LBA-appr.

ASK 21 Flight Manual

Note: During spins the ASK 21 oscillates in pitch. From a steep nose down spin recovery according to the standard procedure is up to 1 turn, from a flat spin less than 1 turn.

The speed at which the stall takes place depends on the payload. The following standard values are applicable:

Single: All up weight 470 kg (1034 lbs):
without airbrakes 65 km/h (35 kts) IAS
with airbrakes 68 km/h (37 kts) IAS

Dual: All up weight 600 kg (1320 lbs):
without airbrakes 74 km/h (40 kts) IAS
with airbrakes 77 km/h (42 kts) IAS

IV.7 HIGH SPEED FLIGHT

The sailplane shows no flutter tendency within the permissible speed range.

With airbrakes extended in a 45° dive the speed remains below V_{NE} = 280 km/h (151 kts); it goes up to 232 km/h (125 kts) at $G = 600$ kg.

IV.8 CLOUD FLYING

For min. equipment for cloud flying see II.3 a and II.3 c.

According to past experiences the airspeed indicator system is not exposed to the danger of icing-up. However with strong icing-up the pilot must be always take into account the possible failure of the airspeed indicator. When planning cloud flying, he must take this point into consideration.

Excessive speeds during cloud flying must be avoided in any case. The pilot should try to keep an average speed of about 100 km/h (54 kts) and with increasing speed above 130 km/h (70 kts) he should use the airbrakes in order to control the speed.

Rev.no./Date Sig.
TN23 Jan.91 Waibel

Author Date
Kaiser April 80

Page no.
LBA- 26
APP.

Attention !!

Cloud flying must only be done by pilots having the necessary licence. The legal regulations with regard to airspace and the requirements for instruments have to be met.

IV.9 AEROBATICS

Attention aerobatic flyers !!

Even a sailplane which is approved for full aerobatics does not have infinite strength capacities. Most hazardous are aerobatics which get out of control or are badly executed, as they result in the high loads.

Therefore, it is urgently recommended to have oneself guided by an experienced flight instructor. The ASK 21 being an approved two-seater for full aerobatics offers this possibility.

Such guidance is even prescribed according to §69 (4) of the German 'LuftPersPO' (Aviation Personnel Test Regulations) dated January 9, 1976. Following §96 (3) of the said 'LuftPersPO' an adequate experience is required from flight instructors.

Note !!

The normal airspeed indicator system shows a large pressure error in inverted flight during which the airspeed indicator reads 40 km/h (22 kts) too low. When extending the pitot head by attaching a brass tube - 12~~8~~ x 1; 140mm (5,5 in) in length -, this error disappears. The tube must project in the front at least 70mm (2,75 in). For normal flights this is not necessary. In order to avoid damage when parking the sailplane in the hangar, this tube should not be left on any longer than necessary.

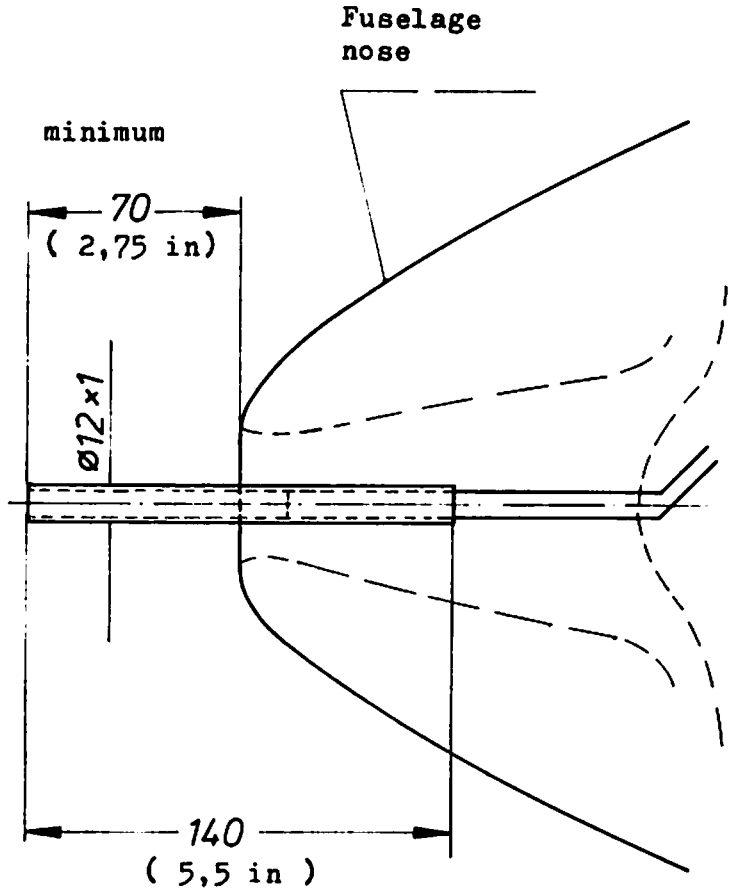

Extension tube for total pressure head with inverted flight. Brass tube 140 mm (5,5 in) in length (12 ø x 1).

One may also use a suitable plastic tube provided that it is sufficiently stiff and straight.

ASK 21 - Flight Manual

For the aerobatics hereafter mentioned the following entrance speeds are recommended :

	<u>Indicated En- trance speed</u>	<u>Max Acce- leration</u>
Loop upward	single : 155km/h (84 kts) dual : 170km/h (92 kts)	2 - 3 g
Stall Turn	single : 165km/h (89 kts) dual : 180km/h (97 kts)	3 g
Split 'S'	single : 170km/h (92 kts) dual : 180km/h (97 kts)	2 - 3 g
Immelmann	single : 165km/h (89 kts) dual : 180km/h (97 kts)	2,5 - 3,5g
Slow Roll	single : 150km/h (81 kts) dual : 165km/h (89 kts)	
Steep Climbing)		
Turns and Lazy)	single : 140km/h (76 kts)	
Eight) dual : 150km/h (81 kts)	
Chandelle	single : 160km/h (86 kts) dual : 175km/h (95 kts)	

Permissible Indicated Speeds

Inverted flight without pitot head extension :

V_{NE} single	65-240 km/h	(35-130 kts)
dual	70-240 km/h	(38-130 kts)

Indicated maneuvering speed V_M	= 140 km/h (76 kts)
Indicated max speed V_{NE}	= 240 km/h (130 kts)

Inverted flight with pitot head extension :

Indicated maneuvering speed V_M	= 180 km/h (97 kts)
Indicated max speed V_{NE}	= 280 km/h (151 kts)
Indicated stall speed	= 87 km/h (47 kts)
	with two occupants

LOOP

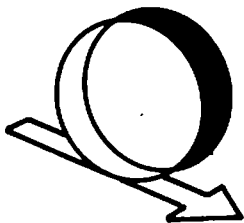

Entrance speed :

single : 155 km/h 84^{kt}

dual : 170 km/h 92^{kt}

max. g = 2 - 3

STALL TURN

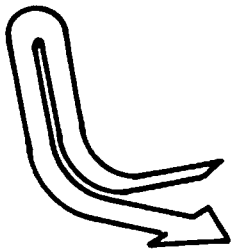

Entrance speed :

single : 165 km/h 90^{kt}

dual : 180 km/h 97^{kt}

max g = 3

SPLIT 'S'

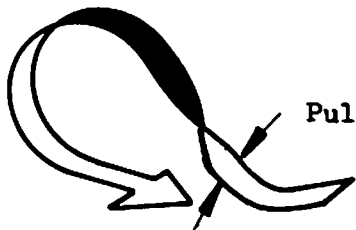

Pull-up at least 30° !

Altitude loss approx. 100 meter

Entrance speed :

single : 170 km/h

dual : 180 km/h

max. g = 2 - 3

IMMELMANN

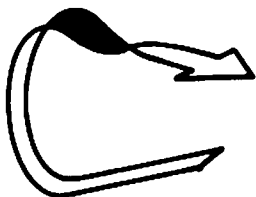

Entrance speed :

single : 165 km/h

90kt

dual : 180 km/h

97kt

max. g = 2,5 - 3,5

SLOW ROLL



Entrance speed :

single : 150 km/h 81 km

dual : 165 km/h 90 km

INVERTED FLIGHT

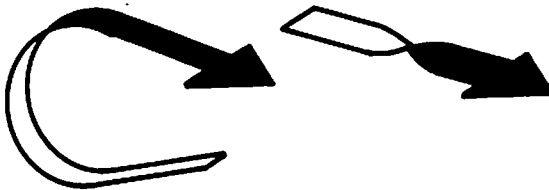

HALF ROLL

HALF LOOP

Note : with the inverted flight the fuselage nose will be unexpectedly high above the horizon.

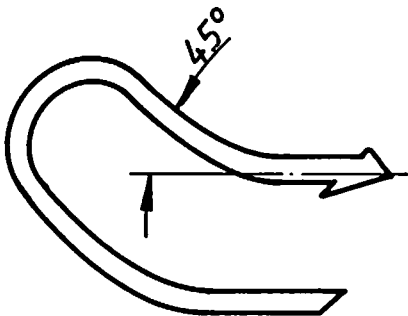

STEEP CLIMBING TURN

Entrance speed :

single : 140 km/h

dual : 150 km/h

CHANDELLE

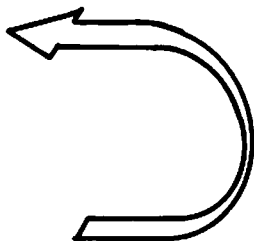

Entrance speed :

single : 160 km/h

dual : 175 km/h

Attention !!

Never release stick and rudder pedals when flying aerobatics.

With aerobatics instruction a reliable agreement must be made between instructor and student flyer with regard to the communication system for the mutual taking over of the controls.

Airbrakes must be extended as soon as the pilot loses the control of the sailplane or as the speed increases unvoluntarily too rapidly.

Exception : "Tail sliding" !!

The trim remains in the center position for aerobatic maneuvers. Don't ever change the trim when flying aerobatics !!

PROHIBITED AEROBATICS :

All abrupt aerobatic maneuvers.

Loop forward.

Tail sliding.

ASK 21 Flight Manual

Attention!

Never release stick and rudder pedals when flying aerobatics.

With aerobatics instruction a reliable agreement must be made between instructor and student flyer with regard to the communication system for the mutual taking over of the controls.

Airbrakes must be extended as soon as the pilot loses the control of the sailplane or as the speed increases unvoluntarily to rapidly.

Exception: „Tail sliding“!

The trim remains in the center position for aerobatic manoeuvres. Don't ever change the trim when flying aerobatics!

With spin ballast is attached, aerobatics are prohibited (except spinning).

10. Prohibited aerobatics

- All abrupt aerobatic manoeuvres.
- Loop forward.
- Tail sliding

IV.10 APPROACH AND LANDING

The most favorable approach speed is about 90 km/h (49 kts). With turbulence it may be advisable to increase the approach speed slightly. Even steep approaches may be slowed down efficiently with the airbrakes. It is advisable to unlock the airbrakes at the beginning of the landing final approach.

Note : The airbrakes increase the stalling speed by about 3 km/h (1,6 knots).

Sideslipping is also suitable as an approach control.

With full rudder during sideslipping the rudder pressure decreases to zero; the rudder must be pushed back.

V. RIGGING AND DE-RIGGING

V.1 RIGGING

Rigging the ASK 21 can be carried out by four persons without mechanical assistance, and by three persons with the use of a fuselage stand or a wing support.

Prior to rigging, clean and grease all pins, bolts, bushings and control system connections !

1. Set up the fuselage and hold it horizontal.
2. Plug the spar fork of the left wing into the fuselage and - if available - place a wing support under the wing end.
3. Offer up the right wing and align the main pin fittings.
4. Press in the main pins and secure. Never insert the rear wing attachment pins prior to the main pins !
5. Press in the rear wing attachment pins; unscrew the T-tool and check whether the safety lock is engaged.
6. Connect and lock the aileron control linkages in the fuselage behind the spar tunnel. You must be able to touch the ball pivot by feeling through the slot in the socket. Also check the proper engagement of the safety lock by pushing it on to close ! Secure them with spring clips!
7. Connect and lock the airbrake control linkages in the fuselage behind the spar tunnel. Secure them with spring clips!

8. The tailplane is fitted onto the fin from the front (see Fig. V.2-1 and V.2-2). Now the Allan bolt at the leading edge is screwed in; this should be screwed in tightly until the spring-loaded safety pin snaps out over the screw head as far as the socket.

9. Connect the elevator and safety with a spring clip !

Note, if your glider uses an automatic elevator connection: after cleaning and lightly greasing the plug-in elevator connections, the tailplane is fitted onto the fin from the front; both elevator panels must be fitted into their connectors simultaneously. Then the tailplane is pushed back until the Allan bolt at the leading edge can be screwed in; this should be screwed in tightly until the spring-loaded safety pin snaps out over the screw head as far as the socket.

10. Carry out a pre-flight check referring to the Check List.

11. The control circuits must be subjected to an operational test.

12. Check condition and function of the wheel brake; check the tire pressure.
See also Section IV.2 Daily Inspections.

V.2 DE-RIGGING

De-rigging is carried out in the reverse sequence to that of rigging. It must be taken care that the rear wing attachment pins have to be removed prior to the main pins.

WARNING: For derigging the horizontal tail from the fin it has to be regarded that only the method according to Fig. V.2-2 is used.

Fig. V.2-1
WRONG: Twist movement

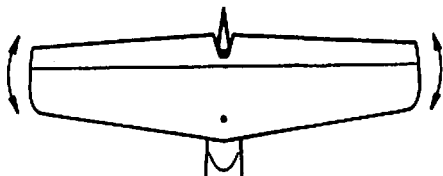

Fig. V.2-2
RIGHT: Pitch movement



V.3 PARKING

When parking the glider, the canopies have to be closed.

When an ASK 21 is parked on an airfield in the sunshine (this must also be observed during the waiting time until take-off when the pilots are already on board) the canopies must not be left open for some time.

Depending on the position of the sun and the intensity of the radiation, the burning-glass effect of the canopies can cause a slow fire in the area of the instrument panel or the headrest respectively.

Therefore, if you have to store the glider outside, it is absolutely necessary always to close the canopies and to cover them with a white cloth.

V.4 ROAD TRANSPORT

The design of a glider trailer is another subject and cannot be discussed in all details here. Of course, a closed trailer is preferable. But also an open trailer may serve the purpose, the latter is generally simpler and lighter. It is important that all components are well fixed and have a large support surface.

Structural components survey drawing which can be used for the building of a trailer, can be obtained from ALEXANDER SCHLEICHER.

WARNING: In no case must the elevator actuator fitting be loaded. This fitting trades out of the upper end of the fin. Not even soft foam cushions are allowed.

For the construction of the trailer for road transport the full freedom from any load must be carefully regarded.

V.5 PREVENTIVE MAINTENANCE

The whole surface of the sailplane is painted with a weather resisting, white polyester coat. Impurities may be washed off with a mild cleansing agent. Heavy impurities may be removed with a polish.

For the paint maintenance only silicone-free agents are to be used (e.g. 1 Z-special cleansing agent-D2 from the company W.Sauer & Co., 5060 Bensberg, W. Germany, or the cleansing polish from the company Lesonal). Though the sailplane is rather insensitive, it should be protected as much as possible against moisture and humidity. If water has soaked into any components, these have to be stored in a dry room and must be turned over frequently.

The canopy is best cleaned with a special plexi-glass cleansing agent, in an emergency lukewarm water will do. Rewipe only with pure, soft leather or with glove cloth. Never wipe on dry plexiglass.

The safety harnesses must be regularly checked for damage and tears. The metal parts of the harnesses must be checked for corrosion.

SHEET:
1 of 1

**Technical Note
for**

**Alexander Schleicher
GmbH & Co.
Segelflugzeugbau
D-6416 Poppenhausen**

Glider model:

ASK 18, ASK 18B	TN-No. 7
ASW 19, ASW 19B	TN-No. 23
ASW 20/20L, ASW 20B/20BL, ASW 20C/20CL	TN-No. 34
ASK 21	TN-No. 21
ASW 22	TN-No. 6
ASK 23, ASK 23B	TN-No. 7
ASH 25,	TN-No. 4

Subject:

New production series tow release couplings for aerotow and winch launch.

Serial number applicability:

ASK 18/18B,	Data Sheet No. L-307,	all serial no.s
ASW 19/19B,	Data Sheet No. L-308,	all serial no.s
ASW 20/20L,	Data Sheet No. L-314,	all serial no.s
ASW 20B/20BL,	Data Sheet No. L-314,	all serial no.s
ASW 20C/20CL,	Data Sheet No. L-314,	all serial no.s
ASK 21,	Data Sheet No. L-339,	all serial no.s
ASW 22,	Data Sheet No. L-351,	all serial no.s
ASK 23/23B,	Data Sheet No. L-353,	all serial no.s
ASH 25,	Data Sheet No. 04.364,	all serial no.s

Compliance:

None; applicable to new built gliders and in case of replacement of tow release couplings.

Reason:

According to the company TOST they have stopped the previous production series of the tow release couplings "Nose tow release coupling E 72/75" and "Safety tow release coupling G 72/73". These have been replaced by the new tow release coupling productions series "Nose tow release coupling E 85" and "Safety tow release coupling Europa G 88". In order to guarantee a problem-free exchange of the previous productions series against the new one, the new tow release couplings show externally almost no differences.

Action:

1. Where replacement is required or where a corresponding installation location is provided the new tow release coupling production series can be installed instead of the previous ones.
2. When this mod is accomplished, a copy of this Technical Note must be inserted as Annex into the Flight and Maintenance Manual of the glider (Operations Manuals respectively). The accomplishment of this action must be entered into the corresponding table in the manuals (the table headline reads: Additions to..., Amendments to ..., Record or Log of Revisions ..).

Notes:

The glider owners must regard the "Operating and Maintenance Instructions" for the new production series tow release couplings issued by TOST and giving the service time until the next overhaul !

Poppenhausen, January 17, 1990

ALEXANDER SCHLEICHER

GmbH & Co.
i.A. *[Signature]*
Lutz-W. Juntow.

The German original of this Technical Note has been approved by the LBA under the date of March 1, 1990 (signature: SCHOLJOWSKI). The translation into English has been done by best knowledge and judgement; in any case of doubt the German original is controlling.

Wichtigste, keine Verwechslung dieser Liefer-
spez. Vernehmung und Maßnahme ohne Text mit
Original, sonst mit erheblichen Nachteilen
verbunden.
Inanspruchnahme vorbehalten bei Schleicher,
sowie dem Rechte für den Fall der Patentierung
oder Erfindungsbüro-Erteilung vorbehalten.

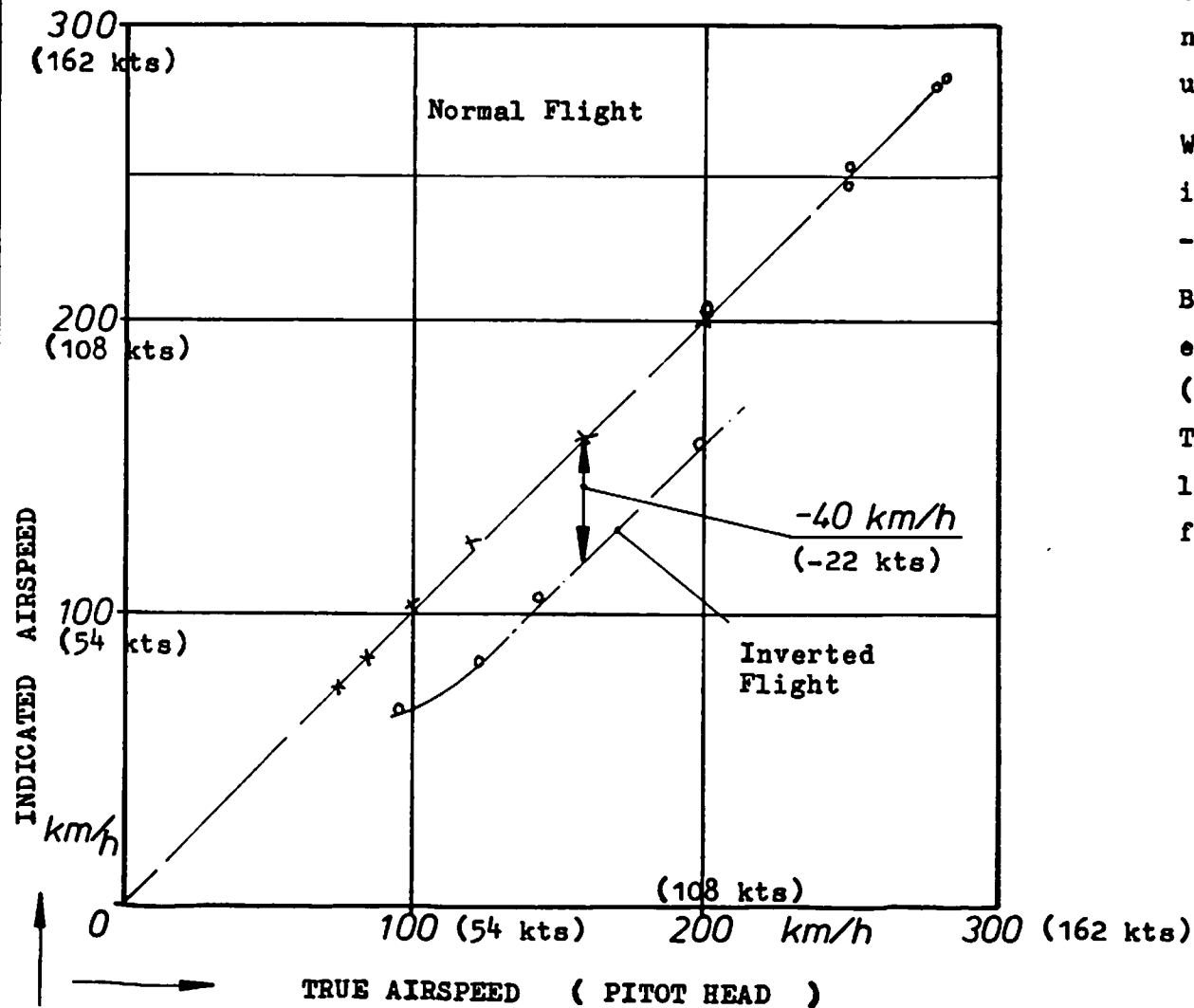

POSITION ERROR

With normal flights the position error of the airspeed indicator is negligible within the whole range up to 280 km/h (151 kts).

With inverted flights the airspeed indicator reads too low, i.e. up to -40 km/h (22 kts).

By attaching an extension tube this error may be eliminated. (see also pages 27/28).

The extension tube must project at least 70 mm (2,75 in) past the fuselage nose.

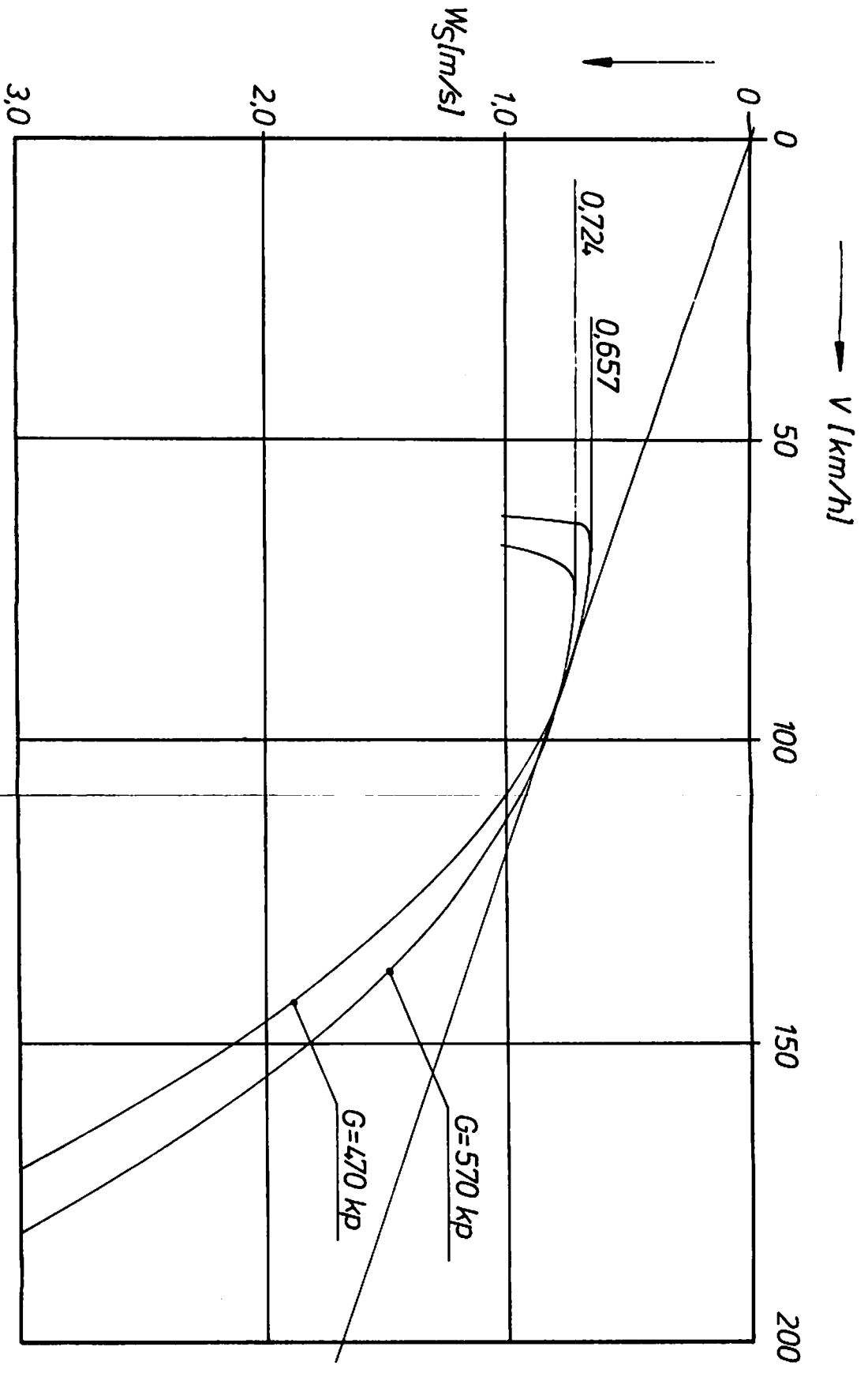

- Ⓜ Clean and lubricate prior to every rigging.
- Disassemble and lubricate on annual inspection.

Lubricate grease nipples if required, but at least once a year.

Clean and oil the tow releases if required.

Cleanse the ball bearings with gasoline and regrease them on annual inspection.

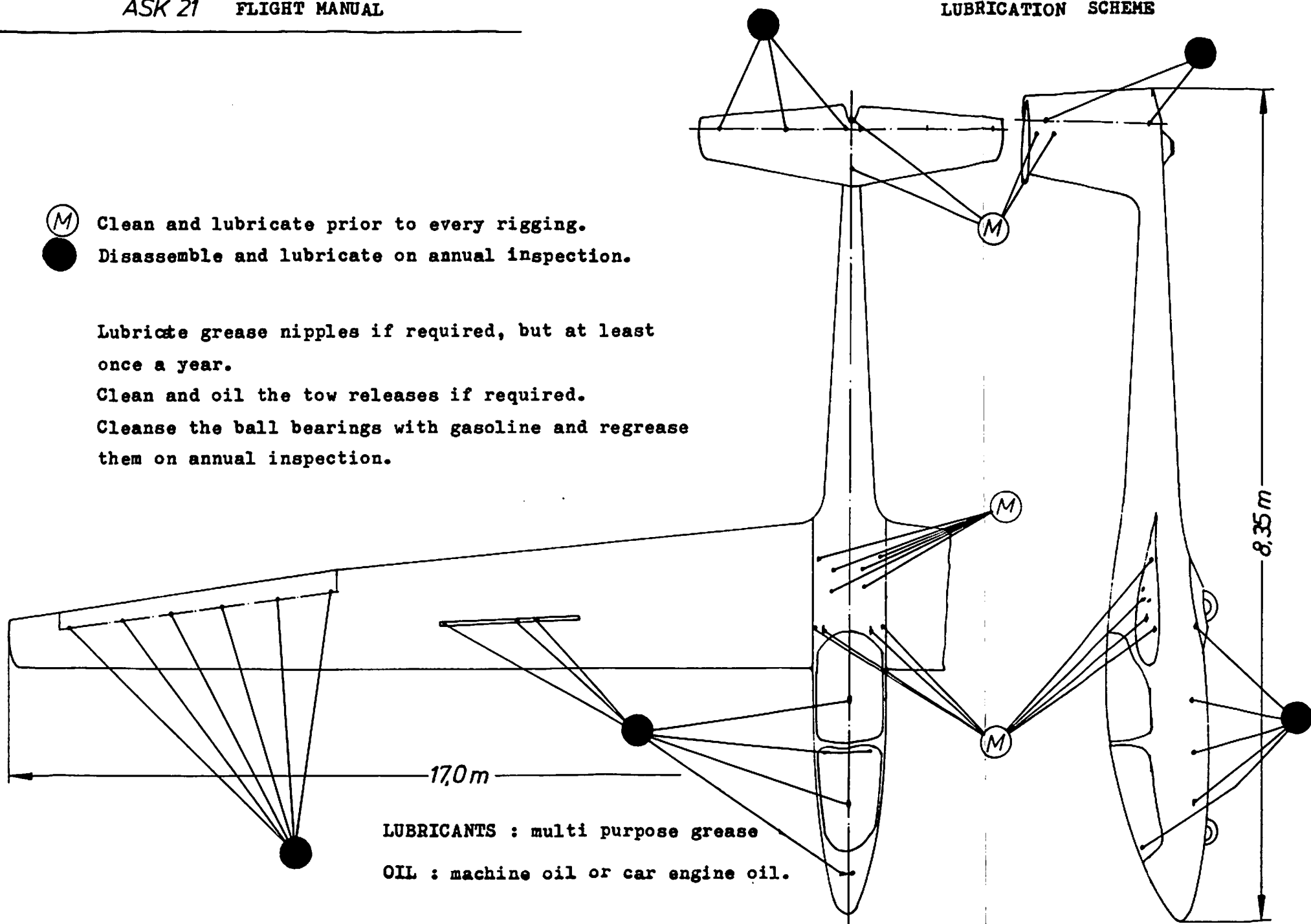

LUBRICANTS : multi purpose grease

OIL : machine oil or car engine oil.

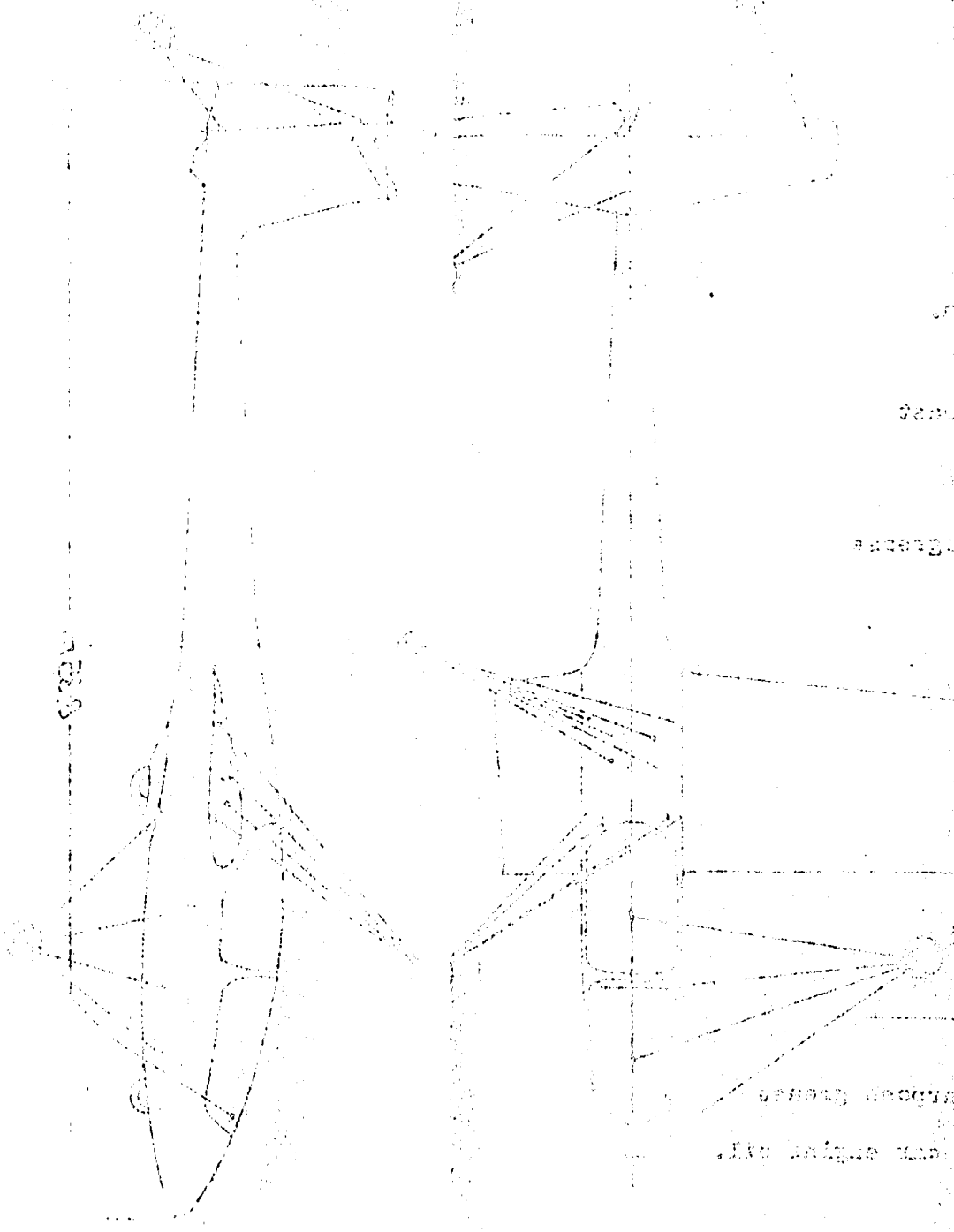

FIG. 1

The present invention relates to a propeller of the type known as a "blade propeller" and is designed to provide a propeller of the type known as a "blade propeller" which is capable of operating at high speeds and is capable of operating at high speeds and is capable of operating at high speeds.

The present invention relates to a propeller of the type known as a "blade propeller" and is designed to provide a propeller of the type known as a "blade propeller" which is capable of operating at high speeds and is capable of operating at high speeds.

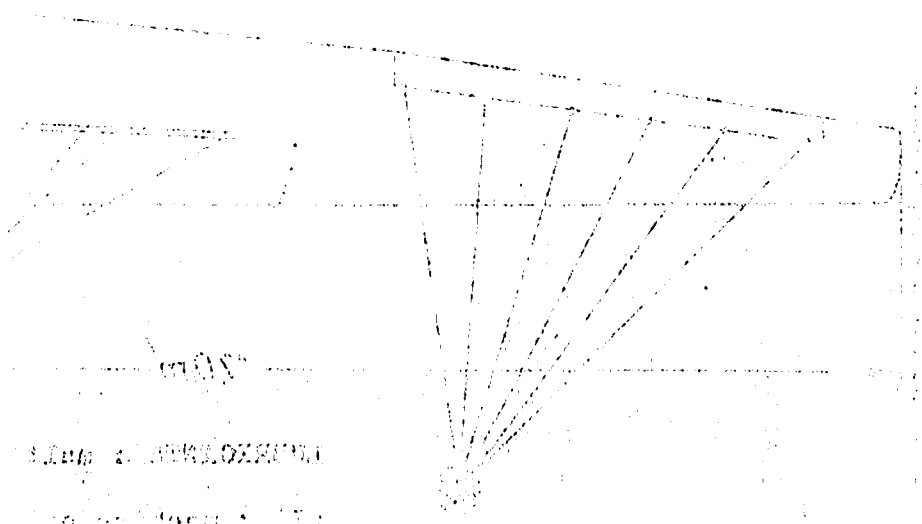

FIG. 2

The present invention relates to a propeller of the type known as a "blade propeller" and is designed to provide a propeller of the type known as a "blade propeller" which is capable of operating at high speeds and is capable of operating at high speeds.