

TWO-SEATER SZD-50-3 "PUCHACZ"  
GLIDER

F L I G H T M A N U A L

=====

Issue 3 - December 1985

This instruction is the part of the  
Airworthiness Certificate of the glider of:

Serial No <sup>1091</sup> B-~~1091~~ Reg.No <sup>9-FEVS</sup> ~~.....~~

This is the translation of the original  
Polish Manual approved by Central  
Administration of Civil Aviation /pages 1-3  
to 5-17 /

Date

Translated by,  
Wiesław Stafiej, D.Sc.



## C O N T E N T S

1. LIST OF REVISIONS
2. OPERATION LIMITATIONS
  - 2.1. Permissible airspeeds
  - 2.2. Limit load factors
  - 2.3. Colour markings of airspeed indicator dial
  - 2.4. Towing cable safety link
  - 2.5. Restrictions
  - 2.6. Messes
  - 2.7. Permissible range of c.g. location
  - 2.8. Table of weighing the glider
  - 2.9. Graphical checking of c.g. location
  - 2.10. Placards and inscriptions.
3. PERFORMANCES
4. GLIDER OPERATION
  - 4.1. Pre-flight inspection
  - 4.2. Cockpits and their arrangements
  - 4.3. Service before take-off
  - 4.4. Controlling
  - 4.5. Aerobatics
  - 4.6. Danger and emergency conditions
  - 4.7. Assembling and disassembling

5. DRAWINGS AND DIAGRAMS .

1. SZD-50-3 "PUCHACZ" glider
2. Installation of board instruments  
Glider with two instrument panels
- 2a. Installation of board instruments  
Glider with one instrument panel
3. Wiring diagram of electric turn  
indicator
4. Speed polar
5. Wings-to-fuselage assembling
6. Assembling of horizontal tailplane
7. Colour markings of airspeed  
indicator dial

APPENDIX

Individual loading plan

1. LIST OF REVISIONS

NOTE:

The place, in which the text has been revised, is marked with vertical line on left side of text and with the number of revision.

Item	Page	Revision	Date	Signature
1	5-4 5-6	On page 5-4 the items 17 and 18, and on page 5-6 the item 16 have been added. The drawings Figs 2 and 2a have been revised.	1987 07-13	



## 2. FLIGHT LIMITATIONS

### 2.1. Permissible airspeeds IAS:

	kts
$V_{NE}$ - max.permissible airspeed in smooth air	116
$V_B$ - max.permissible airspeed in gust conditions	86
$V_A$ - manoeuvring airspeed /speed of full control surface deflection/	81
$V_T$ - max.permissible aerotowing airspeed	81
$V_W$ - max.permissible winch launching airspeed	59
- max.permissible airspeed for extending and flight with airbrake extended	116
- max.permissible airspeed for inverted flight /in smooth air only/	97

### 2.2. Limit load factors

- positive .....	+ 5,3 g
- negative .....	- 2,65 g

2.3. Colour markings of airspeed indicator dial

	kts
$V_{S1}$ /stalling speed/ radial green line at	38
$V_{S1}$ $V_B$ /normal operation range/- green arc at	from 38 to 86
$V_B$ - $V_{NE}$ - higher attention range/yellow arc	from 86 to 116
$V_{NE}$ radial red line at	116

2.4. Towing cable safety link

The safety link of ultimate strength of 1520 lbs  $\pm$  10 % should be installed on the towing cable.

2.5. Restrictions

- SOLO-FLIGHT ALLOWED ON THE FRONT SEAT ONLY.
- GLIDER NOT APPROVED FOR NIGHT FLYING
- FLYING UNDER ICING CONDITIONS NOT RECOMMENDED
- WINCH LAUNCHING WITH C.G. HOOK ONLY
- INVERTED FLIGHT, ROLL AND ASSOCIATED AEROBATICS ACC. TO ITEM 4.5.2. ALLOWED IN THE SMOOTH AIR ONLY AND WITH THE FLOOR BELT OF PILOT'S HARNESS FASTENED  
FLICK ROLL ALLOWED FOR TWO PERSONS CREW ONLY.  
WHEN PERFORMED BY OCCUPANT OF REAR SEAT THE REAR INSTRUMENT PANEL IS OBLIGATORY.

## BGA glider data sheet - Puchacz SZD-50-3

Data source: Flight Manual

Date of issue: Dec 1985

Manufacturer: PZL (Poland)

UK Agent:

Web site:

Phone:

Fax:

Link to mandatory mods:

### Weighing Data:

	Kg	Pounds
Max weight	570	1256
BGA concession non-aerobatic max weight (dry) [+3%]	587	1294
Max weight inverted	540	1190
Max pilot weight (seat load)	110	242
Max pilot weight (seat load) inverted	95	209

mm

Forward C of G limit (aft of datum)	90
Forward C of G limit inverted (aft of datum)	130
Aft C of G limit (aft of datum)	330
Aft C of G limit for flick rolls (aft of datum)	200
Front pilot pos. (forward of datum)*	1270*
Rear pilot pos. (forward of datum)*	137*

### Control deflections in mm

	Up	Down	Measuring point
Ailerons	108/120	54/60	Inboard end
Elevator	198/228	149/169	Inboard end
Rudder	513/567	Both ways	Base
Trim Up to serial No 1081	32/38	72/78	Inboard end
Trim From serial No 1082	28/32	73.5/77.5	Inboard end

\*The flight manual, pages 2-9 & 2-10 quotes different pilot positions for different pilot weights with and without cushions ("pillows"). The figures quoted here are for general use and assume no cushions and a minimum weight front pilot, the most safety critical case.

Longitudinal datum: Wing root LE

Horizontal datum: Datum points on rear fuselage or wing root rib level, using a clear plastic tube filled with water as a level.

### Maximum speeds

	Knots	Kph
VNE	116	215
VNE inverted	97	180
Rough air	86	160
Manoeuvre	81	150

	Knots	Kph
Aerotow	81	150
Winch / auto tow	59	110
Airbrakes open	116	215

Max winch weak link: 758 Kg (Tost Red)

Tyre pressures: Front 17 psi (1,2 Bar), main 43 psi (1,9 Bar), rear 36 psi (2,5bar)

Semi/fully aerobatic - see weight limits Cloud flying permitted

CAIR Aviation "Ottfur" hook(s) may be fitted in place of the original hooks.

This sheet compiled by: Tim Macfadyen

Last update: 27 April 2009 (CAIR Aviation hooks added).

Previous update, 9 April 2009, (pilot positions corrected).

2.6. Masses

lbs

- Max. permissible empty glider mass with standard equipment<sup>x/</sup>..... 816  
in the above included the fuselage with tail unit of ..... 425
- Max. permissible load mass /see page 2-5 /
- Max. permissible load mass in the luggage compartment /see page 2-5 /
- Max. permissible load mass on front seat in:
  - normal flight ..... 240
  - inverted flight<sup>xx/</sup>  
two persons crew ..... 209
- Max. permissible all-up mass in
  - normal flight ..... 1256
  - inverted flight ..... 1190

x/ The standard equipment consists of:

1. Instrument panel /at front seat only/ with airspeed indicator, altimeter, variometer with compensator, slip and turn indicator, compass.
2. Two towing books of SZD-III or TOST type.
3. Two sets of four-belts pilot's harness.
4. Two sets of seat pillows.
5. Assembling wrench
6. First aid kit.

xx/ Inverted flight; the aerobatic manoeuvres listed in item 4.5.2. included.

LOAD IN LUGGAGE COMPARTMENT

Max. load in luggage compartment is 44 lb. The above load comprises the fixed equipment /battery, transceiver block etc./ and a hand luggage. The mass of luggage uniformly distributed in the compartment does not contribute to the c.g location of glider in flight.

The hand luggage should be immobilized by means of cord or belt using the six removable lugs on compartment floor.

2.7. Allowed range of c.g.location /in respect to wing root leading edge/:

- empty glider without the balancing weights: 24 to 25,7 in

- glider in normal flight: 3,6 to 13,1 in

what corresponds to the range of: 23,5 to 44,0 per cent of M.S.G.

- glider in inverted flight: 5,2 to 13,1 in

what corresponds to the range of: 27,0 to 44,0 per cent of M.S.C.

- for performing the flick-roll: 5,2 to 8,0 in

what corresponds to the range of: 27,0 to 33,0 per cent of M.S.C.

Drawing PT B-110-0-1141-2800/104/2

2.8. Table of weighing the glider Fact. No .....

Empty glider mass with standard equipment $m_0$ /lbs/	814.		
Location of c.g for empty glider with standard equipment in respect to root chord leading edge $X_0$ /in/	24,9		
Static moment of mass of empty glider with standard equipment in respect to root chord leading edge: $M_0 = m_0 \cdot X_0$ /lbin/	20268		
Max. permissible loading mass $= 1256 - m_0$ /lbs/	442		
Max. permissible loading mass in inverted flight $= 1190 - m_0$ /lbs/	376		
Date, signature and seal of inspection representant	6.11.1989. 		

285

2.9. Graphical checking of c.g. location

/see diagram on page 2-11 /

Before the flying day or before the every change of loading condition the c.g. location of the glider-in-flight shall be checked; acc. to the following procedure:

1. Add the masses of

- empty glider  $m_0$

/see table on page 2-5 /

- pilots with parachutes  $m_1 + m_2$

- additional equipment and balancing weights incorporated  $m_3$

/see table on page 2-7 /

The resultant mass of the glider-in-flight mark on the vertical axis of diagram on page

$$m = m_0 + m_1 + m_2 + m_3$$

2. Add /algebraical/, respecting the sing/ the mass moments of:

- empty glider  $M_0$  /see the table on page 2-5 /

- pilots with parachutes  $M_1 + M_2$

/see tables on pages 2-9 and 2-10 /

- additional equipment and balancing weights  $M_3$  incorporated /see table on page 2-7 /

Equipment	Mass lbs	Moment lbin
Instrument panel of rear seat	11,5	-347,3
RS-6101-1 transceiver	15,9	+173,6
TA - O3-A Oxygen equipment	40,8	+ 86,8
1 balancing weight	13,9	- 955,0
2 balancing weights	27,1	-1910,0
Snow-ski installed on glider	25,3	-26,1
Luggage-stored in the luggage compartment	44,1	+938,3

The resultant value of glider mass-moment:

$M = M_0 + M_1 + M_2 + M_3$  mark on the  
horizontal axis of diagram on page

3. From the points marked on the diagram axes on page 16 draw the perpendicular lines to the axes and find the point of intersection.

If this point is located in the dashed field of the diagram c.g. is in the correct position.

If this point is located out of the dashed field the c.g. location shall be corrected with the balancing weights and c.g. location checked once more.

Moment of pilot's mass at front seat in respect to wing root leading edge  $M_1$  /lb.in/

Pilot's mass $m_1$ /lbs/	Moment of pilot's mass $M_1$ /lb.in/	
	without pillow	with pillow
121,3	- 6063,6	- 6398,4
125	- 6262,8	- 6607,2
130	- 6531,6	- 6890,4
135	- 6792,0	- 7164,0
140	- 7064,4	- 7449,6
145	- 7336,8	- 7736,4
150	- 7599,6	- 8012,4
155	- 7875,6	- 8302,8
160	- 8152,8	- 8593,2
165	- 8418,0	- 8872,8
170	- 8697,6	- 9166,8
175	- 8978,4	- 9460,8
180	- 9248,4	- 9744,0
185	- 9531,6	- 10040,4
190	- 9816,0	- 10339,2
195	- 10100,4	- 10638,0
200	- 10375,2	
205	- 10663,2	
210	- 10951,2	
215	- 11229,6	
220	- 11521,2	
240	- 12684,0	

Moment of pilot's mass at rear seat in respect to wing root leading edge  $M_2$  /lb-in/

Pilot's mass $m_2$ /lbs/	Moment of pilot's mass $M_2$ /lb-in/	
	without pillow	with pillow
121,3	- 1165,2	- 1498,8
125	- 1184,4	- 1528,8
130	- 1209,6	- 1567,2
135	- 1231,2	- 1603,2
140	- 1252,8	- 1638
145	- 1272,0	- 1674,0
150	- 1298,8	- 1709,6
155	- 1304,4	- 1731,6
160	- 1330	- 1757,2
165	- 1329,6	- 1784,4
170	- 1340,4	- 1803,4
175	- 1348,8	- 1831,2
180	- 1354,8	- 1850,4
185	- 1359,6	- 1859,6
190	- 1363,2	- 1867,6
195	- 1364,4	- 1899,6
200	- 1364,4	
205	- 1362	
210	- 1356,4	
215	- 1352,4	
220	- 1344	
225	- 1332,6	
230	- 1324,8	
235	- 1311,6	
240	- 1297,2	
242,6	- 1288,8	

GRAPHICAL CHECKING OF IN FLIGHT C.G. LOCATION

Diagram valid for gliders of maximum allowable empty glider mass  
/with standard equipment/ of 815,7 lbs.

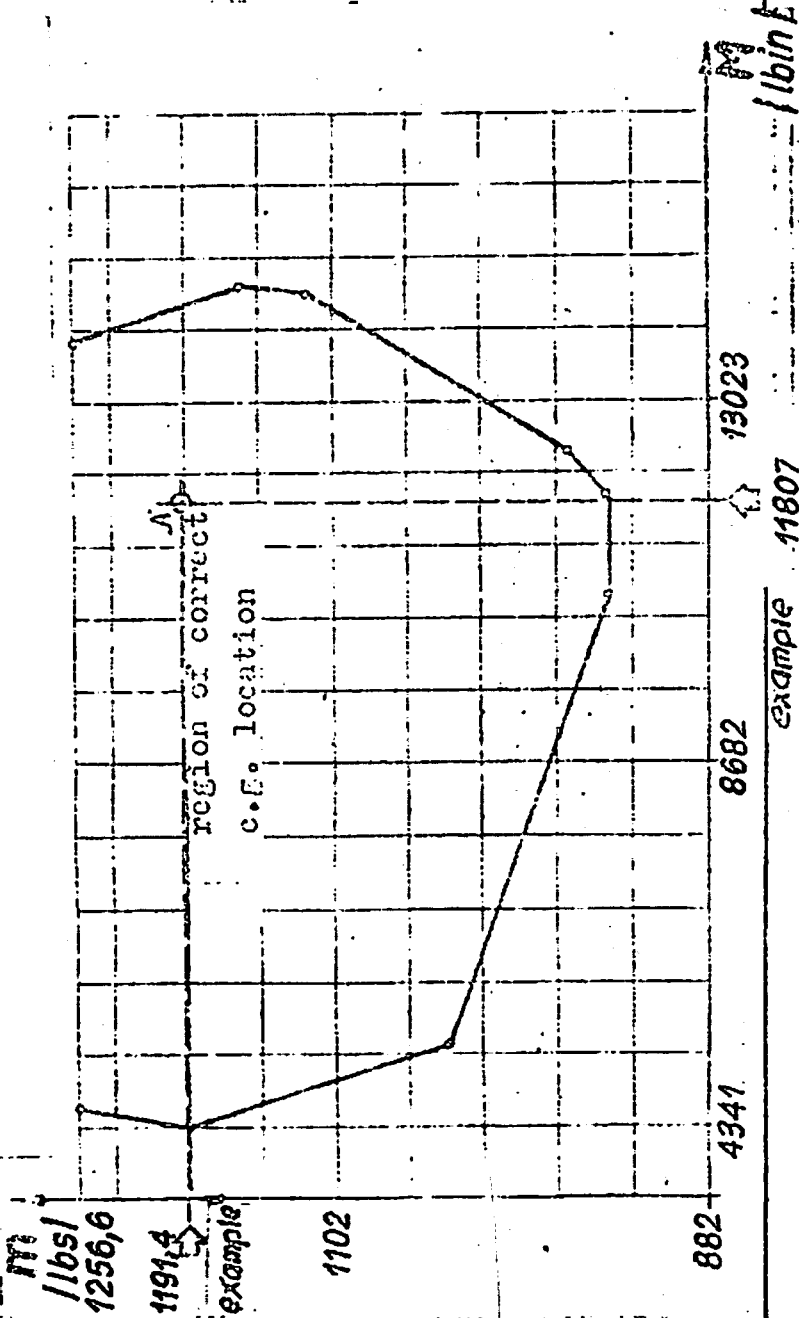

**EXAMPLE:**

Individual data of empty glider /from table of weighing the glider on page 2-5/ c.g. :

$$m_0 = 820 \text{ lbs}$$

$$M_0 = 20400 \text{ lbin}$$

Crew:

Front seat

pilot with pillow  $m_1 = 132 \text{ lbs}$ ,  $M_1 = -7032 \text{ lbin}$

Rear seat

pilot without pillow  $m_2 = 212 \text{ lbs}$ ,  $M_2 = -1390 \text{ lbin}$

Additional equipment

- Instrument panel of rear seat

$$11,5 \text{ lbs} = 347 \text{ lbin}$$

- transceiver ----- 15,9 kg + 174 lbin

$$m_w = 27,4 \text{ kg} \quad M_w = -173 \text{ lbin}$$

Glider-in-flight mass:

$$m = 820 + 132 + 212 + 27,4 = 1191,4 \text{ lbs}$$

Moment of glider-in-flight mass:

$$M = 20400 - 7032 - 1390 - 173 = 11805 \text{ lbin}$$

The perpendicular lines from points

$m = 1191,4 \text{ lbs}$  and  $M = 11805 \text{ lbin}$  on diagram of page 2-11 cross in point A which is in the dashed field. The glider-in-flight c.g. location is correct.

2.10. Placards and inscriptions  
Loading plan placard.

LOADING PLAN

SZD-50-3  
"PUCHACZ"

MAXIMUM ALL-UP MASS IN:  
- normal flight 1256 lbs  
- inverted flight 1191 lbs

MAXIMUM FRONT SEAT LOAD MASS IN:  
- normal and inverted one person flight 240 lbs  
- inverted two persons flight 209 lbs

MINIMUM FRONT SEAT MASS 122 lbs

USE OF BALANCING WEIGHTS  
- for cockpit load mass up to 155 lbs OBLIGATORY  
- for cockpit load mass above 220 lbs PROHIBITED

MAXIMUM LOAD MASS IN LUGGAGE COMPARTMENT 44 lbs

SOLO FLIGHT ON FRONT SEAT ONLY  
IF THE FRONT SEAT OCCUPANT MASS EXCEEDS 220 lbs IT IS PROHIBITED  
FOR THE OCCUPANT OF THE REAR SEAT TO USE THE ADDITIONAL BACK  
PILLOW IF HIS MASS /PARACHUTE INCLUDED/ EXCEEDS 165 lbs.

Placard of permissible airspeeds:

	IAS	fts
SZD-50-3 "PUCHACZ" MAXIMUM PERMISSIBLE AIRSPEEDS		
NORMAL FLIGHT IN:		
- smooth air	VNE =	116
- gust conditions	VB =	86
INVERTED FLIGHT IN:		
- smooth air		97
- gust air		not allowed
MANOEUVRING AIRSPEED /airspeed for abrupt deflection of controls/:	VA =	81
AEROTOWING	VT =	81
WINCH-LAUNCHING	VW =	59
AIRBRAKE EXTENDING and flight with air brake extended		116

Placard of restrictions

RESTRICTIONS

- GLIDER NOT APPROVED FOR NIGHT-FLYING.
- WINCH TAKE-OFFS ALLOWED WHEN USED THE BOTTOM HOOK ONLY.
- FLYING UNDER ICING CONDITIONS NOT RECOMMENDED.
- INVERTED FLIGHT, ROLL AND ASSOCIATED AEROBATIC MANOEUVRES - allowed in smooth air only and with floor-belt fastened.
- FLICK RODL - only with two occupants
- PERFORMING OF THESE MANOEUVRES BY THE REAR OCCUPANT allowed only when the rear instrument panel is installed

Placards of handless

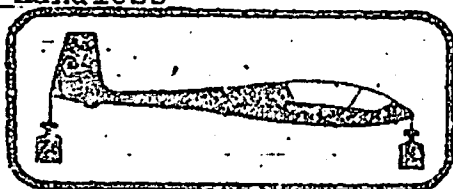

Trimming tab slider -  
- placard on the L.H. board at front and rear seat

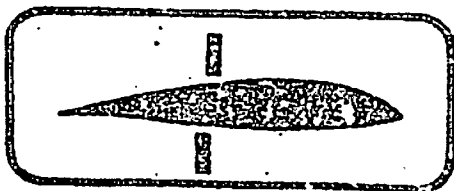

Air brake slider  
- placard on the L.H. board at front and rear seat

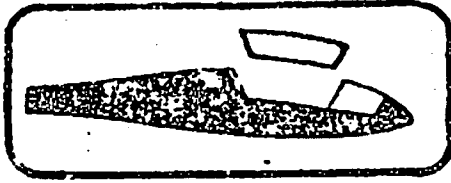

**Canopy emergency jettisoning lock**

- placard on the canopy frame at front and rear seat

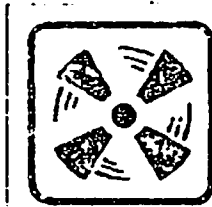

**Air-conditioning tab slider**

- placard on the instrument panel at front seat



**Pedal adjustment**

- placard at front seat floor, before the control column

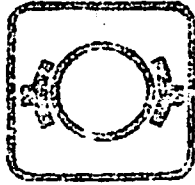

**Wheel brake**

- placard on the L.H. board at front and rear seat



**Towing cable release**

- placard on the L.H. board at front and rear seat.

3. PERFORMANCES /Fig. 4/

Calculated speed polar plotted on Fig. 4 has the following main points:

- min. sinking speed 138 ft/min at about 40 kts
- max. lift /drag ratio 30:1 at about 46 kts

Other points of the polar:

V kts	43	54	65	75,5	86	97
W ft/min	142	187	262	378	537	738

where: V - airspeed

W - sinking speed

#### 4. GLIDER OPERATION

##### 4.1. Pre-flight inspection:

Check for:

- validity of inspection certificate in the glider log-book,
- the integrity of structure and covering,
- locking of fittings and control system joints,
- control system operation,
- towing-hook operation,
- locking and opening of canopy and the condition of canopy in open position securing cable,
- condition of undercarriage, wheel rollability, air pressure in tires /by eye/,
- locking of seat and back-rest at rear seat,
- pilot's safety belts,
- ports of total and static pressure,
- operation of airspeed indicator /it should operate when blowing on ports/ x/
- operation of slip-and-turn indicator x/

---

x/ In the rear instrument panel also, if installed.

#### 4.2. Cockpits and their arrangements

The standard equipment comprises one instrument panel at front seat only. The instruments are located in such a way that they are satisfactorily visible from the rear seat also.

During the flight the upper panel edge allows for controlling the glider in respect to horizon, or in respect to towing aeroplane.

Additionally the glider can be equipped with the second instrument panel mounted on the canopy.

The cockpit is designed to use back-type parachutes or pillows of 4,7 in thickness when pressed. The front seat allows for the pilot above 6,6ft tall.

The pedals are adjustable in flight /5 positions/; adjustment of pedals is made by feet when the knob on the floor /painted brown/ is pulled. The pilots having short legs or small mass should use the additional cushion on the backrest.

The rear seat allows for the pilot above 6,6ft tall. The seat pan is adjusted on the ground /vertically and longitudinally/ by shifting the backrest cross tube /4 positions/. When the position is adjusted the cross tube should be secured with the lock.

In general, the higher pilot's position in the rear seat; the better is the visibility forward including the instrument panel at the front seat. Pilots having the short legs should use the additional back rest pillow.

The standard equipment comprises four belt pilot's harness at both seats. The installation of the floor-belt /additional equipment/ is possible.

Fastening of the floor-belt is obligatory for flight in which the inverted flying and associated aerobacy manoeuvres /controlled roll; controlled half-roll-half-loop; controlled half-loop-half-roll/ are intended. In other flights when the floor-belt is out of operation it should be placed below the seat pillow and immobilized by means of the button. The cockpit is closed with the integral perspex canopy fixed on two hinges on the R.H. board with the possibility of emergency jettisoning.

The opened canopy is hold up with a cable which when closing the canopy pulls up automatically into the winding set behind the front seat back rest.

Both seats have the control columns coupled each other; the pedals and other control levers are marked with placards. Operation of controls is of conventional type.

The handles are arranged as follows:

Control system	Position of handle	Colour of handle
Air brake slider	on the left	blue
Wheel brake knob	on the left	black
Trimming tab slider	on the left	green
Towing cable release handle	on the left	yellow
Canopy locking lever	on the left	red
Canopy emergency jettison handle	on the right	red /sealed with lead/

The cockpit is air conditioned with the side windows in the canopy, separate for the front and rear seat.

The front seat has adjusted inflation on the perspex front part above the instrument panel operated by the slider in the panel /black ball-knob/.

Both seat have side pockets accessible in the flight.

Two nests for balancing weights are located before the front seat.

The weights of mass 13,9 lbs each are not interchangeable. They are fixed on bolts with tommy-bars without using of tools.

In the cockpit and the luggage compartment the fittings for the oxygen equipment and transceiver are installed.

#### 4.3. Service before take-off

##### 4.3.1. Transportation on the airfield

During the transportation of the glider the cockpit should be locked and the windows opened. The air brakes can be extended or retracted.

The glider / with or without the occupants/ can be towed by the front hook or by the tail lug having the possibility of free turns. The ground towing cable length should be at least 4m.

The glider can be also rolled on wheels forward or backward. At turns the tail should be pressed or the nose lifted.

#### 4.3.2. Adjusting of the rear seat height

The rear seat can be adjusted in an unloaded condition as follows:

1. Open the canopy and the securing tab on the L.H. fuselage surface under the wing /accessible from inside/.
2. Shift the supporting tube to the left up to release the seat pan.
3. Set the seat in the required position, put on the supporting tube and close the securing tab.

#### 4.3.3. Locking of hooks

In the gliders having TOST hooks they are operated from cockpit by pulling the releasing knob, when the knob is free the hooks close automatically. In the gliders having SZD-III hooks each one hook opens independently when the rear hook positioned tension cable is pulled.

#### 4.3.4. Filling the tube with air

It is necessary to use the extending end. The main wheel valve is located on the R.H. side and is accessible after shield deflection. Pressure 42,6 psi. The front wheel valve is located on the L.H. side.  
Pressure: 17. psi.

#### 4.3.5. Drainage of ducts

- Remove the pressure ducts of the rear seat instrument panel /3a and 3b Fig. 2/ and plug them on the port end.
- Detach the drainage units from the ducts of the front seat instrument panel /in points marked with arrows in Fig. 2/ and blow through the drainage units together with port ducts;
- screw out the drainage unit bowls, take out and dry the inserts. Install the dried elements and bowls /tighten firmly/.
- connect the drainage units free ducts to the rear seat instrument panel,
- check the operation of airspeed indicator /it should operate when blowing on ports/.

#### 4.3.6. Assembling of balancing weights

Put the weight into proper nest and screw on full the clamping screw.

#### 4.3.7. Procedures before take-off

1. Balance the glider with balancing weights according to the crew mass and if necessary put on the back cushion /small or light weight pilot/.
2. Adjust the rear seat correctly. Before the solo flight clamp the free belts and protect /or remove/ the contents of side pockets in the rear cockpit.

3. Take place in the cockpit, adjust the pedals and fasten the belts.
4. Check full movements of controls, air brake and trimming tab. Retract the air brake. Set the trimming tab slider according to the take-off method and crew mass.
5. Check the operation of turn indicator.
6. Close the canopy.
7. Insert the cable into the hook and check the locking pulling it firmly.

#### 4.3.8. Post-flight procedures

- Switch off the turn indicator. If necessary remove the used batteries.
- If necessary drain the instrument installation according to 4.3.5.
- Inspect the glider as before take-off and remove the eventual failures.

#### 4.4. Controlling

##### 4.4.1. General characteristics of controlling

The SZD-50-3 "PUCHACZ" glider allows for correct and easy controlling as do it most of the modern performance sailplanes.

Characteristics:

- short and well shock-absorbed ground run;
- good lateral and directional controllability;
- safe low speed behaviours without the excessive inclination to

spinning,

4.4.2. Take-off and flight in aerotowing  
/front hook/

Pay attention to have the towing cable straight-tensioned before take-off. According to the crew mass adjust the balancing tab:

- solo flight - "nose heavy"
- heavy crew - "neutral"

The ground run begins on two wheels. At the airspeed of about 16-22 kts the front wheel should be lifted by pulling slightly the stick, when avoiding to hit the ground with the tail skid. According to the all-up mass the glider airborns at speed of 35 to 41 kts. When the flight becomes stable correct the setting of trimming tab.

Recommended towing airspeeds:

- at climb 51 to 65 kts
- at cross-country flight 65 to 81 kts.

4.4.3. Winch-launching /bottom hook/

Before take-off the glider should be positioned in line with towing cable. The slight directional deviation is allowed to the left of a cable but, the deviation to the right should be avoided in respect to the possibility of front wheel to the cable contact during the ground run /the possible touching or even the rolling of the front wheel through the tensioned cable does not create, however, any danger, nor disturbs the ground run/.

The adjusting of the trimming tab according to the pilot's mass on the front seat.

- solo light weight pilot - "nose heavy"
- mean pilot - "nose heavy"
- heavy crew - "neutral"

The adjustment of the tab should not be corrected during take-off

The glider ground run /initially on two wheels, next on the main wheel/ is correct, and the run length depends on the crew mass and take-off conditions. After airborning fly correctly near ground avoiding the tail skid to ground contact and pass into steep climbing.

With glider correctly balanced the stick forces are not large, and with incorrect balance the forces are not excessive.

The launching speed should be 49 - 54 kts /not less than 43 kts/.

In the final climb phase slightly pull the stick.

Before releasing the cable put the stick forwards to discharge the cable. During intended self-releasing the stick should be pulled forward after the releasing.

After releasing the cable, pull the releasing handle once more and pass into the normal glide.

Depending on the glider all-up mass and the winch power with a cable 1800 ft long in smooth air the gained height reaches 660 - 820 ft.

#### 4.4.4. Longitudinal trim in free flight

The trimming tab allows for glider trim:

- for solo light weight pilot - within the airspeed range of 32 to 81 kts.
- for heavy crew - within the airspeed range of about 42 to about 116 kts.

#### 4.4.5. Stalling /airspeeds IAS/

Depending on the glider all-up mass the stalling speed in the straight flight is of about 31 kts for solo lightweight pilot to about 38,8 kts /heavy crew and all-up mass of about 1256 lbs/.

The stall warning is in form of perceptible vibrations of fuselage, oscillations of airspeed and "over horizon" attitude. When stalled the glider drops down symmetrically in general and /at further pulling the stick/ with tendency to drop the wing. The stall in turn is preceded by distinct inclination to decrease the turn radius. With further pulling the stick glider drops with tendency to increase the bank.

If, however, the tendency to decrease the turn radius is prevented with proper aileron counter action, the stalled and strongly vibrating glider turns without dropping.

With air brakes extended the stalling speed in straight flight is of about 35 to about 41 kts depending on all-up mass.

In all the cases of stalling the glider allows for recovering the normal flight reliably by the resolute elevator

deflection and if necessary by the other control deflection for balancing the bank.

#### 4.4.6. Circling

When circling in thermals the glider has very good lateral; controllability. The circling speed is of 38 to 49 kts depending on all-up mass, bank and flight conditions.

#### 4.4.7. Spinning

Before the intended spinning in one person flight the pilot of mass below 165 lbs should check the proper glider balancing with weights.

When entering the spinning in the straight flight it is recommended, for making it easy, to have a little bank towards the intended spinning direction. It is also possible to enter the spinning in the turn.

In both the cases it is recommended to decrease the airspeed by slow pulling the stick and in the moment of stall initiation to pull the stick full. Deflect the rudder towards the intended spinning. The recommended aileron deflections are listed in table on page 4-13. To obtain the stable spinning especially in the case of heavy crew the precise full deflection of elevator is necessary /with the comparatively high force depending on the crew mass/. When the above directions are observed the glider performs the steady spinning with the characteristics described in the table on page 4-13

NOTE: The table of spinning characteristics is not the loading plan. The table concerns glider with all the additional equipment variants acc to the loading plan on page 2-13

The aileron deflection towards the spin favours the appearance or augmentation of longitudinal oscillations /especially in the solo spinning with light weight pilot/ and therefore it is not recommended.

The not full deflection of elevator /specially with heavy crew/ leads to the airspeed increasing up to 54 kts or more and even the automatic break of the spinning.

The recommended recovery technique consists of:

- full rudder deflection opposite to the rotation; a considerable leg force is required
- waiting for about 1 sec.
- pushing the stick forward more than to its neutral position.

The maksimum delay when this technique is used is lower then 1 turn.

In case of other technique or not resolute action the delay can be more than 1 turn.



4.4.8. Sideslip - can be performed in 2 ways:

a/ With simultaneous; gradual deflection of ailerons and rudder at the airspeed of about 70 - 80 km/h, the directional sideslip with bank of to 10 - 15° is obtained. Indications of airspeed indicator drop below 50 km/h. Keeping up the rudder deflection requires the applying of resolute force on pedal; releasing of this force causes the automatic neutralizing of rudder and the glider passes into a turn towards the bank. With the bank of above 15° the glider also turns towards the bank.

b/ With deflection of controls in an order: at first the ailerons, then rudder, when the bank of ~ 15° is obtained, the glider allows to enter into directional sideslip with bank of up to about 30°. During deflection of rudder the force on pedal disappears simultaneously it appears the impulse to raise the glider nose above the horizon.

It is necessary, in this moment, to stabilize the glider by pulling back the stick. Indications of the airspeed indicator in this condition drop down to about 0.

When recovering with aileron and rudder deflections simultaneously /it is necessary the resolute deflection of rudder towards the bank/ the glider passes into the turn.

When recovering with aileron at first as the bank diminishes the rudder is neutralized automatically and the glider passes gradually to

the straight flight; such a recovery is a little slower than the previous one.

#### 4.4.9. Air brake

The air brake is very efficient and can be, if necessary, extended in full range of permissible airspeeds.

The effectiveness of brakes allows to avoid the use of sideslips during normal approach to landing.

#### 4.4.10. Landing.

Generally the landing should be performed against the wind. If necessary the landing with the side wind up to 10 kts or the back wind up to 6 kts is allowed when paying special attention.

The recommended approach speeds:

- in smooth air 49 - 54 kts depending on all-up mass,
- in turbulent air 54 - 60 kts depending on all-up mass.

The flying-path inclination should be adjusted by the air brake.

According to all-up mass and air brake travel the touch-down with the main wheel follows at airspeed of about 35 to 41 kts.

It is recommended to touch-down with the partly extended air brake.

After touch-down the glider rolls at first on the main shock-absorbed wheel. Then smoothly drops the front wheel this effect can be delayed /to diminish the shock during rolling/ with gradual pulling of stick.

The length of landing run in windless condition is:

- without use of wheel brake - about 295 - 360 ft depending on all-up mass;
- with use of wheel brake - about 200-260 ft depending on all-up mass.

#### 4. Aerobatics

Before take-off for aerobatics it's necessary to:

- check the correct glider balance with balancing weights /concerns solo flight/
- remove the free elements out of the cockpit;
- check the locking of back rest tube at the rear seat,
- check the full deflections of controls having the belts fastened;
- before the solo flight remove the needless pillows and fasten the pilot's harness at the rear seat.

In the flight just before performing the manoeuvres it's necessary to:

- fasten the back belts,
- balance the glider with trimming-tab on the airspeed of 60 - 65 kts i.e. similar as for towed flight,
- check the locking of canopy and air brake;
- shut the window and air-conditioning tab.

The schooling in aerobatics can be performed in the good horizon visibility conditions only.

4.5.1. The following manoeuvres can be performed without fastening the floor-belt

MANOEUVRE	initial airspeed	
	/ kts /	
	crew	
	one person	two persons
Looping*, stall turn	86 - 97	90 - 105
Spiral	65	70
Quick half-roll-half-loop	51	54
Chandelle	81	97
Lazy eight	81	97
Cuban eight	86 - 97	90 - 105
Leaf slides	stalling speed	

RECOMMENDATIONS FOR MANOEUVRES

- General - In manoeuvres requiring the considerable use of elevator /looping; quick half-roll-half-loop/ the increased forces on the stick are required specially in flight with heavy crew.
- Looping; stall-turn; spiral - Performing is conventional

- Quick half-roll-half-loop - At the initial airspeed of 51/54 kts the autorotational half-turn is obtained when the stick is resolutely pulled full with simultaneous full deflection of rudder. The further rotation is braked by means of neutralization of controls. Recovery is performed by means of semi-loop downwards.

Chandelle - At the initial air speed of 81/97 kts the glider should be entered into the sharp climbed turn with 45° bank with such an attention that when recovered for the returned direction /180°/ the airspeed ranged 38-43 kts .

Lazy eight - At the initial airspeed of 81/97 kts the glider should be centered into the sharp climbed turn with 45° bank with such an attention that when the direction changed by 180° the turning airspeed was about 43 kts .  
After the next 45° the glider should be recovered out of the turn the airspeed of 75,5/81 kts gained once-more and the same manoeuvre performed into the reversal direction, then recovered into the original direction.

Cuban eight - At the airspeed of 85 - 97/ 90-105 kts the looping should be initiated. In the upper /inverted/ attitude, when the inverted horizon is seen, pull the stick full and deflect the rudder full.

The glider continues the loop and passes into 3/4 attitude making the quick autorotational vertical turn /towards the deflected rudder/. When the turn reached 180° the stick should be resolutely pushed and the rudder neutralized to brake the further turn and to retain the glider in diving in direction reversal in respect to original one.

When the airspeed reached 90 kts perform the second looping and recover into the normal flight.

Leaf-slides - /dallying with stall/. Enter the stalling on the same way as for the spinning and immediately break the turn using the opposite rudder deflection and short pulling the stick. Then pull the stick once-more and deflect the rudder till to the stalling into the opposite direction etc.

4.5.2. The following manoeuvres can be performed only when the correct location and fastening of all 5 belts of pilot's harness is observed.

	initial airspeed	
	/ kts /	
	Crew	
	one person	two persons
Entering the inverted flight by means of half-roll	75,5	81
Entering the inverted flight by means of half-loop	90	97
Straight inverted flight	70	75,5
Turns in inverted flight	70	75,5
Recovering from inverted into normal flight by means of half-roll	75,5	75,5
Recovering from inverted into normal flight by means of half loop	59	65
Controlled roll	90	98
Controlled half-roll-half-loop	75,5	81
Half-loop-half-roll	108	113
Flick roll	57	59

To perform the above manoeuvres by the rear occupant of two persons crew the installation of rear instrument panel is obligatory.

#### RECOMMENDATIONS FOR MANOEUVRES

- Entering the inverted flight by means of half-roll.

At the initial airspeed of 75,5/ 81 kts the glider should be slightly pulled above the horizon and simultaneously the rotation initiated using the full aileron deflection. Before passing the 90° position the glider should be hold above the horizon by means of deflection the rudder in direction opposite to bank /using the "upper leg"/. Then gradually release the elevator /the full deflection, if necessary/ and neutralize the rudder. In the 180° position break the rotation of the glider /neutralize the aileron/ and recover the airspeed to 65 kts retaining the "above horizon" attitude. Correct the eventual bank.

- Entering the inverted flight by means of half-loop

At the initial airspeed 90/ 97 kts perform the first half-loop. In the inverted position prior to the nose drop below the horizon pull the stick resolutely and set the inverted flight airspeed into 65 kts in "above horizon" position. In case the airspeed increases unintended, open the airbrake in advance.

In respect to a low tolerance of angle in the moment of breaking the loop and the low margin of permissible airspeed in inverted flight this manoeuvre can be learned when the inverted flight is completely familiar to the pilot.

- Straight inverted flight.

The glider should be retained in "above horizon" attitude with the airspeed of 65 - 70 kts. When correcting the banks pay attention that the stick side movement e.g. to right results the RIGHT wing to be elevated above the horizon and vice versa.

In the prolonged inverted flight the trimming, if necessary, should be set into "nose heavy" position, using even the full range of trimming.

In the straight flight the stalling at about 59 kts airspeed is possible. It requires the full stick movement forwards. When the glider drops down the stick should be slightly pulled for a moment then once more pushed to get the "above horizon" attitude.

- Turns in inverted flight

The bank of glider, when introduced into the turn, is obtained by means of side deflection of the stick in the direction opposite to the intended turn direction.

It is recommended to control the glider with the small deflections of aileron and rudder.

The airspeed in turn is 75,5 kts .

- Recovering from inverted into normal flight by means of half-roll.

Increase the airspeed in inverted flight up to 75,5 kts. Then push the stick to obtain the above horizon position and move the stick to aileron direction /full aileron deflection/. When passing the 270° position retain the glider above the horizon by means of smooth deflection of rudder /in accord to aileron deflection/ and neutralize the elevator.

In normal position neutralize the aileron and rudder and return to the steady flight.

- Recovering from inverted into normal flight by means of half-loop.

In the inverted flight with the airspeed below 59- 65 kts gently pull the stick. In the diving the airspeed should be controlled and the glider recovered into the normal flight on the arc-path of semi-loop.

In case the airspeed increases considerably, the air brake should be extended in advance.

- Controlled roll In the normal flight

at the airspeed of 97 kts the glider should be elevated slightly above the horizon. In the same time the rotation should be initiated by means of aileron deflection. Before passing the 90° position the glider should be retained above the horizon using the smooth rudder deflection in the direction opposite to bank /use of "upper leg"/.

Then gradually release the stick and neutralize the rudder.

When the 180° position passed, gradually deflect the rudder in accord to the aileron.

When passing the 270° position retain the glider on horizon using the rudder deflection in accord to the aileron.

In the normal position neutralize the aileron and rudder and return to the steady flight.

NOTE: Having some experience the rolls can be performed with the initial airspeed of 85 kts

- Controlled half-roll-half-loop.

Perform the first half of controlled roll with initial airspeed of 75,5/ 81 kts . In the inverted position decrease the airspeed up to 59 kts .

Then pull the stick passing into the half-loop.

Pay attention that the airspeed must not exceed 116 kts - if necessary extend the air brake in advance.

Recover the glider from diving into the normal flight.

- Half-loop-half-roll

At the initial airspeed of 108 kts perform the first half of looping in such a way that the airspeed in the inverted position would not drop below 59 kts .

In the inverted position push the stick forwards resolutely and then perform the second half of controlled roll /deflect the aileron, retain the glider above the horizon by means of rudder deflections in accord to the aileron/.

When entering the normal position neutralize the aileron and rudder and return to the steady flight.

- Flick roll

In respect to the troubles in correct controlling of the flick roll at the rear location of glider c.g. this manoeuvre should be limited to two persons crew only. Performing of flick roll depends on the extorting of autorotation by means of simultaneous full stick pulling and full rudder deflection towards the intended rotation direction. During the autorotation the airspeed decreases considerably. Therefore to avoid the stalling and unpleasant dropping of the glider at the end of the manoeuvre it is recommended to initiate the flick roll with the position pitched clearly below the horizon.

In the steep diving accelerate the glider to 57-59 kts /not more ! / then simultaneously pull the stick full and deflect full the rudder.

The glider performs the autorotation in respect to longitudinal axis with the tendency to climbing. Before gaining the 360° position neutralize the controls to break the rotation.

If necessary finish the rotation with the aileron and return to the normal flight.

#### 4.5.3. Inverted spinning

In respect to the fact that the steady inverted spinning is not possible to be performed in the greater part of c.g. location range this manoeuvre is not allowed.

In the case of unintended developing of inverted spinning as a consequence of inverted stalling the stick should be pulled immediately and the other controls neutralized. The glider breaks the rotation nearly immediately and passes into diving.

It should be recovered slowly controlling the airspeed.

If necessary, extend the airbrakes in advance.

The recovering from inverted spinning into the inverted flight is prohibited!

#### 4.6. Danger and emergency conditions procedures

##### 4.6.1. Break or unintended releasing of tow-cable at low height

1. Release the hook /if the cable remained with glider/.
2. Bring the glider to correct glide.
3. Land in place chosen with respect to the wind direction and other landing conditions.

##### 4.6.2. Flight with incorrect trim

- a/ In case of lack of required number of balancing weights /solo light weight pilot/ - interrupt the flight and land on the airfield avoiding the stall.

b/ Excess of weights /heavy crew/

- interrupt the flight and land on the airfield.

4.6.3. Danger of exceeding of the maximum permissible airspeed

In case the airspeed unintended increases creating the danger of exceeding the allowed value in normal flight /116 kts / or in inverted flight / 97 kts / the air brake shall be extended in advance and the proper action for decreasing the airspeed and making the flight steady should be taken.

In such situations the considerable stick pulling is not allowed.

4.6.4. Emergency jettisoning and use of parachute

- a/ Decision to leave the glider:  
Leaving the glider is the obligatory crew rescue, when it is impossible to land on the ground in controlled way, as e.g.:
- in case of fire or technical fault making impossible the controlled flight;
  - in case of sudden, severe mis-disposition of pilot during the flight /e.g. injured eyes/;
  - in case of impossible return to the ground /e.g. the, extensive fog region/

The decision of leaving the glider is taken by the ship-captain.

b/ Sequence of leaving the glider. The crew member being not the ship-captain leaves the glider first. The ship-captain leaves the glider in second sequence after using all the possibilities to enable the second crew member to leave the glider.

c/ Sequence of procedures:

1. Release the control stick
2. Hold firmly and push forwards simultaneously:
  - canopy lock handle with left hand,
  - canopy emergency jettisoning lever /with right hand/.
3. When holding the handles push the canopy and jettison out.
4. Release the safety belts.
5. Fold the legs and jump out of the cockpit. If the glider gets the quick rotational movement - jump towards the centre of rotation.
6. Wait at least 3 sec. to get a distance in respect to glider and open the parachute.

d/ Procedures in special cases:

- If the canopy does not allow to be jettisoned, destroy the perspex, starting from the windows. If necessary use the action of legs.
- If the cockpit leaving occurs on the altitude below 660 ft open the parachute immediately paying

attention to avoid a collision of the parachute and glider structure or another crew member.

- If the cockpit leaving follows on the high altitude take into consideration:

- a/ danger of further climbing on parachute in the strong climbing currents /in a cloud/ and danger of on oxygen lack; low temperature, or icing.

- b/ danger of freezing the body at delayed parachute opening.

In respect to these circumstances it is recommended to stay in the cockpit of damaged glider /if its condition allows for/ until it descends to the altitude of conditions for safe parachute use.

- If the damaged glider allows for the limited control and the altitude does not require the immediate cockpit leaving the ship-captain can help the pupil in leaving the cockpit /e.g. giving instructions or maintaining the convenient flight condition/ acc. to his decision e.g.:

- when controlling the glider to order the pupil to jettison the canopy and leave the cockpit

- delay the jettisoning of the canopy or after jettisoning to control the glider again.

#### 4.7. Assembling and disassembling /Fig. 5 and 6/

##### 4.7.1. Tools

- assembling lever for fitting the spars
- screwdriver
- pliers
- pin for service of tail plane securing bolt.

##### 4.7.2. Assembling staff: min. 4 persons

##### 4.7.3. Assembling procedures

1. Clean and grease the working surfaces of disconnected fittings and joints.
2. Put the fuselage on the assembly stand. Support the front wheel /tail skid on the ground/
3. Take off the fuselage upper inspection door. Retract the air brake in wings, set up the brake slider in the cockpit in the front position and the control stick in the plane of glider symmetry.
4. Insert the R.H. wing to the fuselage acc. to Fig. 5 /aileron to the neutral position, air brake retracted/.
5. Insert the L.H. wing to the fuselage keeping the ailerons in the neutral position. Obtain the connection of pivots and nests, as well as elements coupling the control system.  
After having wings in position lock the spars finally by the lever installed on spar feet acc. to Fig. 5b.  
Insert the main pin, insert the rommy-bar into the hole in glass-fibre member

and secure with the safety pin.

6. Assemble the R.H. half of a tailplane with the vertical stabilizer acc. to Fig. 6 /insert the tubular spar end and the front fixing pivot into proper nests/.

Connect the control system joint /set up the elevator and trimming tab properly/.

7. Slide on the L.H. half of a tailplane on the tubular spar protruding from the L.H. side of a vertical stabilizer. Pull forward the protruding end of securing pin and lock it turning by  $90^{\circ}$ . Connect the control system joints /set up properly the elevator and trimming-tab/. After connecting the L.H. half of a tailplane turn the securing pin by  $90^{\circ}$  and press it back /red mark must disappear/.

8. Check all the connections and operation of controls. Close the fuselage upper inspection door.

#### 4.7.4. Assembling procedures

1. Pull forward the protruding pin securing the L.H. half of tailplane and lock turning it by  $90^{\circ}$  /red mark on the pin should be visible/.
2. Take off at first the L.H. and then the R.H. half of the tailplane /pull outside applying the oscillating motions to loosen the connection/. If necessary beat the carrying tube end using the hammer and the wooden block.
3. Retract the air brake and take off the safety-pin which secures the main pin. Support the wing ends and take out the pin.

4. Support the wing ends, put on the assembling lever on the spar foot and loosen the connection of spars with motion of a lever.  
Next support the fuselage and take off at first the L.H. and next the R.H. wing.  
Install the main pin into the fuselage fitting and secure with safety-pin.

5. DRAWINGS AND DIAGRAMS

Fig. 1. SZD-50-3 PUCHACZ glider

16570

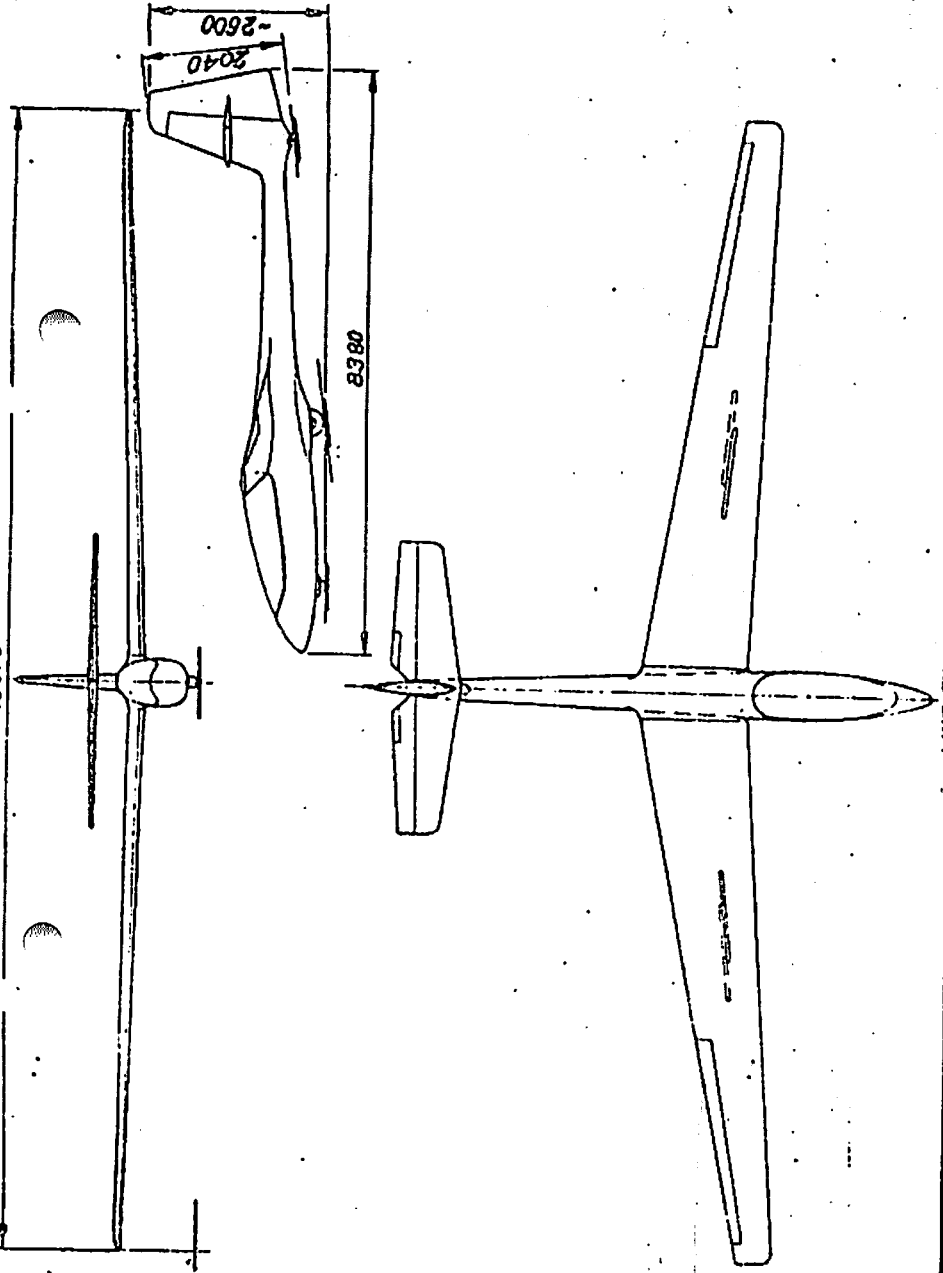



Fig. 1

**Fig. 2. Installation of board instruments.**

**Glider with two instrument panels.**

- A - Instrument panel of front seat
- B - Instrument panel of rear seat
- C - Location of panels, ports and ducts in fuselage
- 1 - Total pressure port
- 2  - Static pressure port
- 3a - Total pressure duct end in fuselage /bottom/
- 3b - Static pressure duct end in fuselage /upper/
- 4 - Rubber ducts
- 5a - Total pressure duct end of rear instrument panel
- 5b - Static pressure duct end of front instrument panel
- 6 - Drainage unit
- 7 - Bottle
- 8 - Compensator
- 9 - Airspeed indicator
- 10 - Variometer
- 11 - Altimeter
- 12 - Turn indicator
- 13 - Compass
- 14 - Turn indicator battery socket
- 15 - Turn indicator switch
- 1  - Nuts fixing the rear instrument panel to canopy

Arrows mark the drainage unit end which should be disconnected when draining the installation.

- 17 - K-1 tube
- 18 - K-1 tube duct

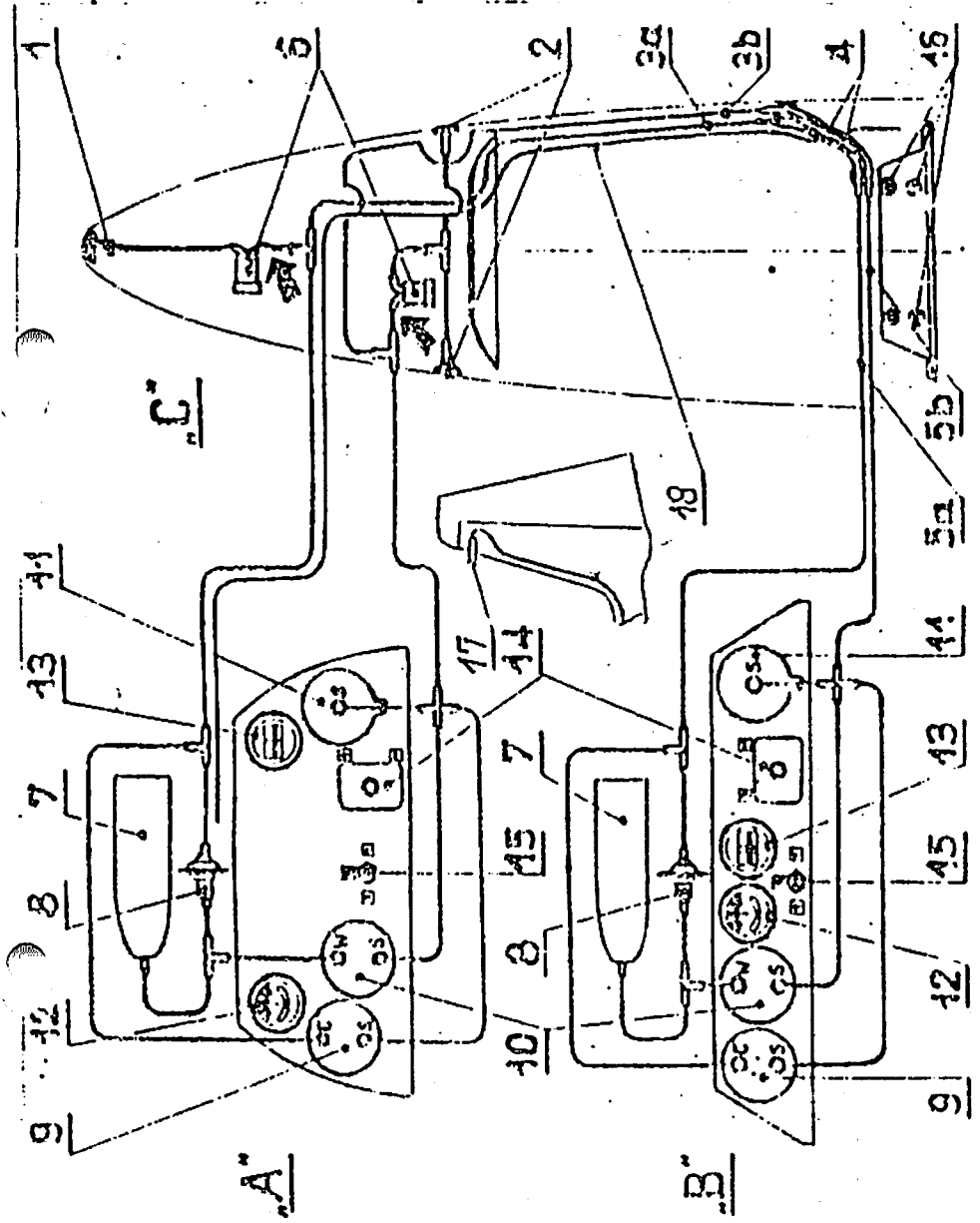

Fig. 2

Fig. 2a. Installation of board instruments  
Glider wit one instrument panel

- 1 - Total pressure port
- 2 - Static pressure port
- 6 - Drainage unit
- 7 - Bottle
- 8 - Compensator
- 9 - Airspeed indicator
- 10 - Variometer
- 11 - Altimeter
- 12 - Turn indicator
- 13 - Compass
- 14 - Turn iddicator battery socket
- 15 - Turn indicator swith

Arrows mark the drainage units ends 6,  
which should be disconnected when  
draining the installation.

16 - K-1 tube duct

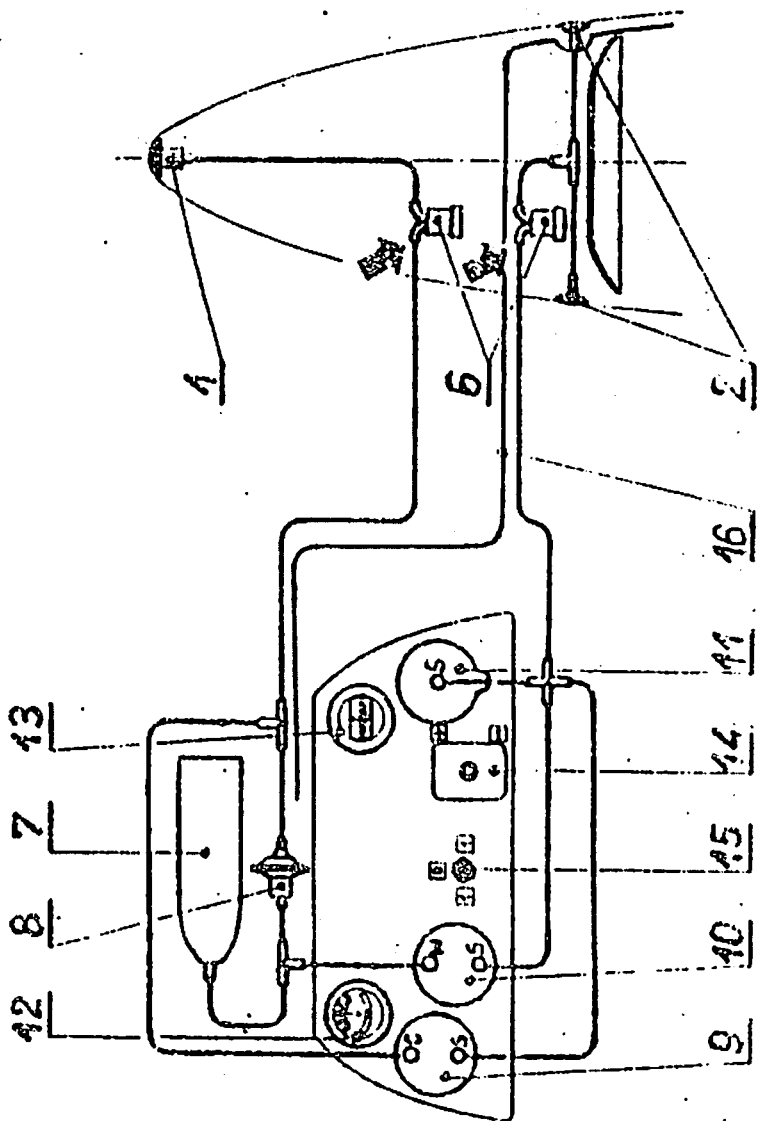

Fig. 2a

Fig. 3. Wiring diagram of electric turn indicator

- 1 - Turn indicator
- 2 - Switch
- 3 - Batteries /the poles arrangement shown on drawing/

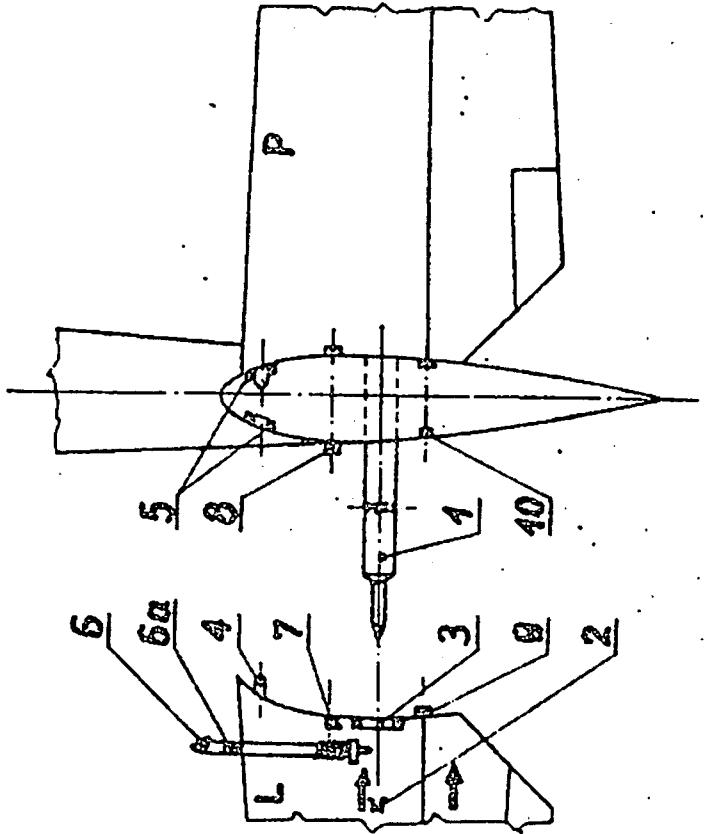

Fig. 6

0-3  
M3

5-9

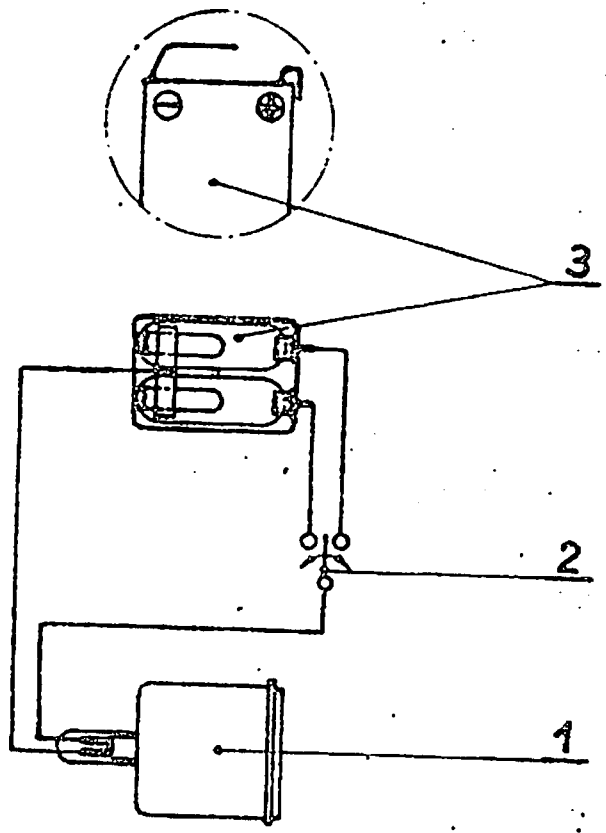
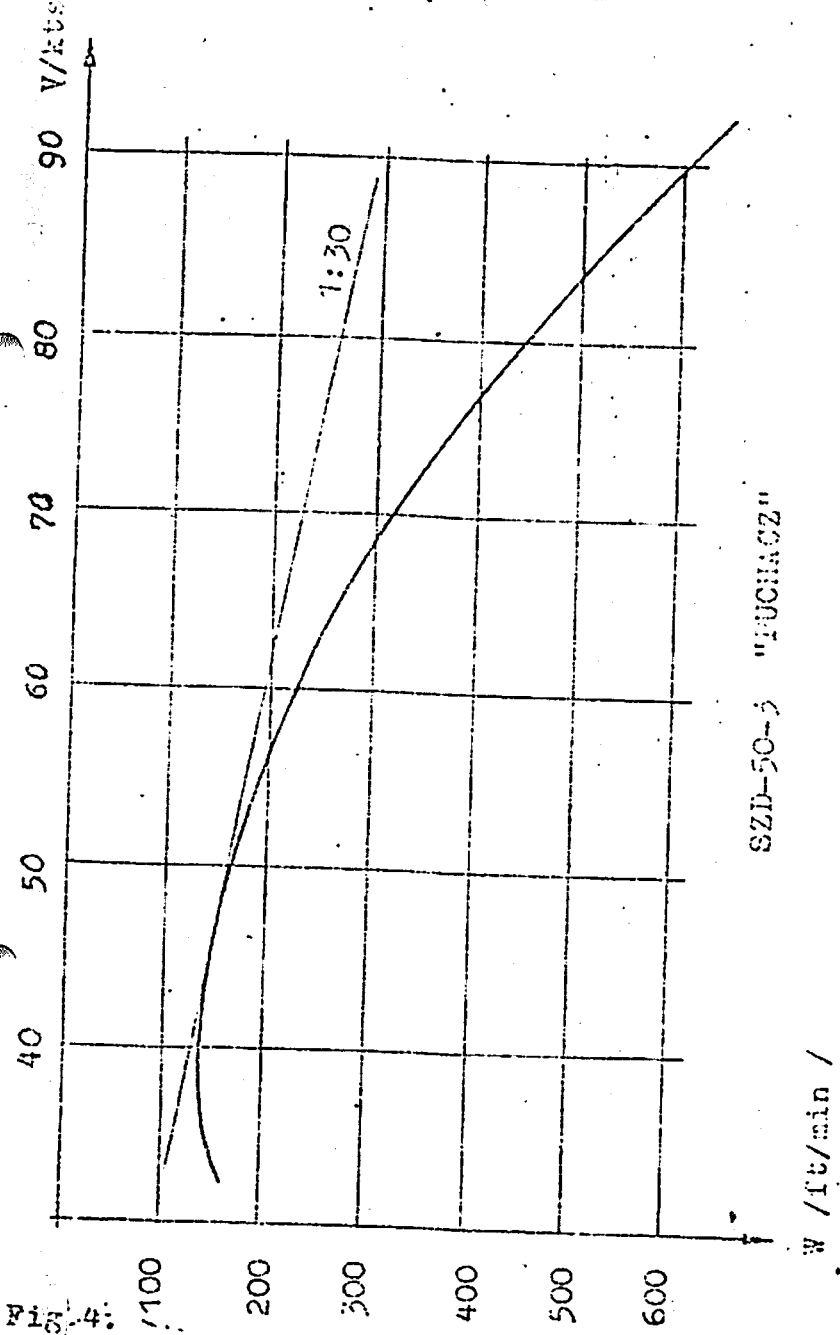

Fig. 3

Flight measured

Fig. 4. Speed polar



SZD-50-3 "PUCHACZ"

Fig. 4:



## Fig. 5. Wings-fuselage assembling

a/ R.H. wing fitted to fuselage

L.H. wing prepared for fitting

b/ Locking the spars by means of assembling lever attached on thrust pivots.

Full arrow: rigging. Broken arrow: derrigging

- 1  Spar root pivots
  - 2 - Fuselage pivots
  - 3 - Self-aligning nests in wings
  - 4 - Control system joints in wings
  - 5 - Air brake control system joints in fuselage
  - 6 - Aileron control system joints in wings
  - 7 - Aileron control system joints in fuselage
  - 8 - Main bolt with tommy-bar
  - 9 - Safety - pin
  - 10 - Spar thrust pivots
  - 11 - Assembling lever
- P  R.H. wing  
L - L.H. wing  
K - Fuselage

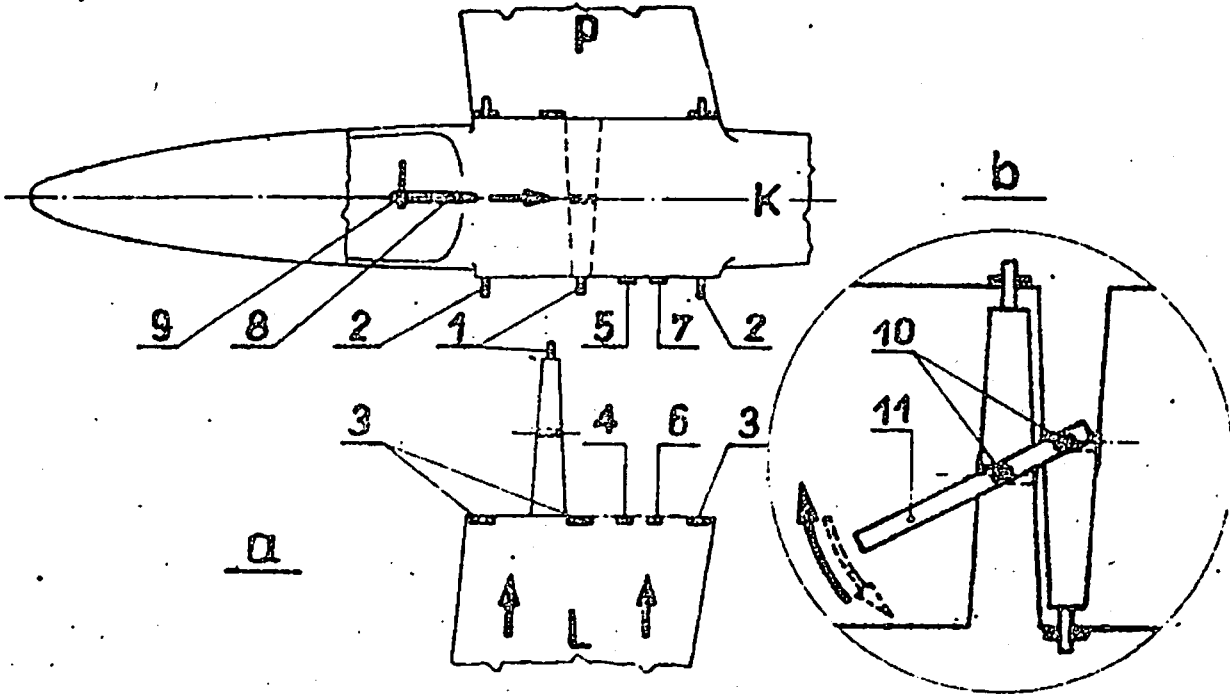

DAVID W. PETERSON - BOSTON / 10009 400/42

FIG. 5

**Fig. 6. Assembling of horizontal tailplane**

**P - R.H. half tailplane /with carrying tube/ fitted with fin**

**L - L.H. half of tailplane with trimming-tab**

**1 - Carrying tube**

**2,3 - Carrying tube nests in L.H. half**

**4 - Pivot fixing fin half**

**5 - Securing pin in dissecured position /protruded forward/, secured position /small hole in vertical position/.**

Red caution sign visible in this position disappears when the pin is pressed in.

**7 - Trimming-tab control joint on L.H. half of control surface**

**8 - Trimming-tab control joint on vertical stabilizer**

**9 - Control joint on elevator**

**10 - Elevator control joint on vertical stabilizer**

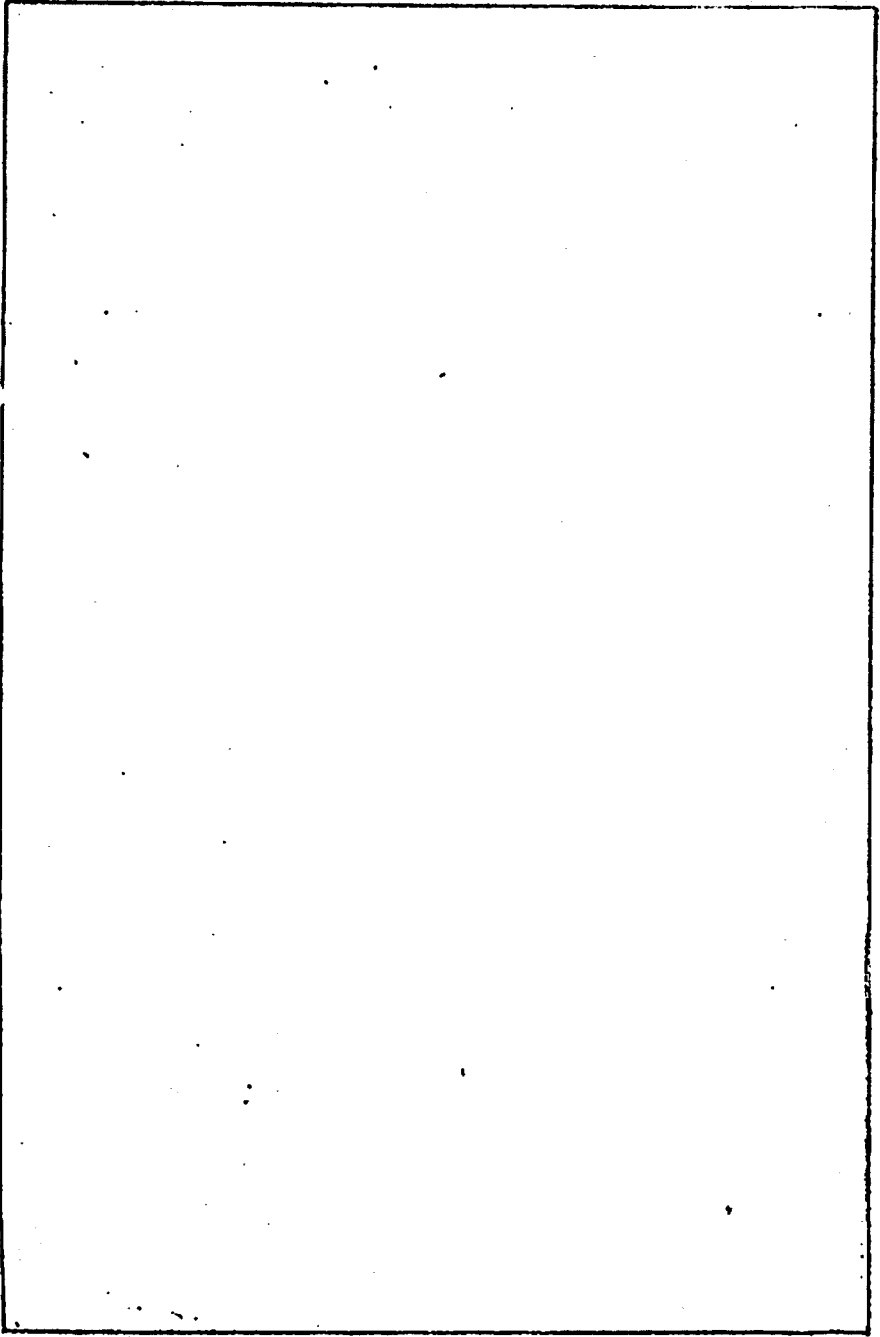

Fig. 7.

Colour markings of airspeed indicator dial



- red



- yellow



- green

0-3  
M3

- 5-17 -

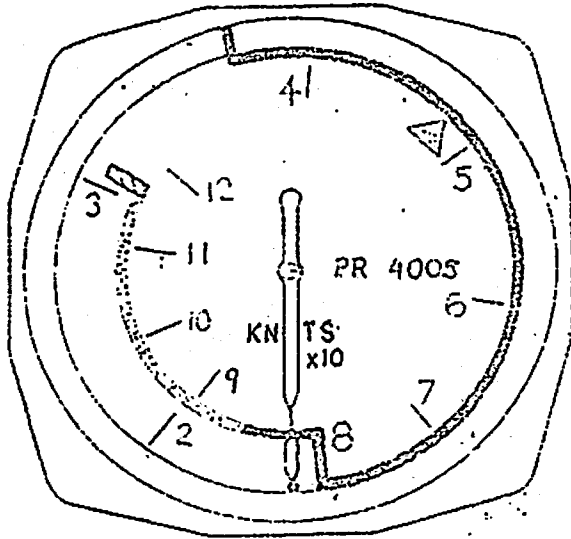

A P P E N D I X

Individual loading plan

During the daily operation of the glider the simplified method of checking the loading mass and defining the balancing weights amount can be applied on base of the table of individual loading plan /page 6-3/.

Rules for use the individual loading plan

1. The balancing weights are required only in solo flight if the pilot's mass is lower than 155 lbs.
2. The total load mass defined as the sum of real crew mass /parachute included/ and eventual luggage cannot exceed to maximum value listed in the table.
3. Mass of single crew member /parachute included/ cannot exceed 240 lbs.
4. The mass of front seat occupant in the inverted two persons flight must not exceed 209,5 lbs.

Rules for inscriptions to the table of individual loading plan.

1. The inscriptions are made by Techn. Check. Dept. of producer or work-shop which performed the repair or replacement of additional equipment.

2. Every time two tables are fulfilled: one remains in this Manual, the second one is to be stored in the pocket provided in the cockpit. In case the revision is made the page 6-3 of Flight Manual should be replaced with the new one with actual data.

On the same way prepare the new table on page 6-4 cut it off and place in the cockpit.

It should be inscribed:

- Fact. No of glider
- Actual additional equipment /transceiver oxygen equipment, rear instrument panel/.
- Empty glider mass with standard equipment and additional equipment installed.
- Max. total load mass /crew with: parachutes and luggage/ equal to the subtraction of:  
1256 lbs- total mass of empty glider with standard equipment and additional equipment installed.
- Max. pilot's mass /parachute included/ on front seat defined as the subtraction of max. load mas-pilot's mass /parachute included/ on rear seat. If the value so calculated exceed 240 lbs the value of 240 lbs should be inscribed. If the inscribed value for two persons flight exceeds 209,5 lbs the sign  $\times$  should be added.
- Date, seal and signature of Techn. Check. Dept.



*British Gliding Association*

## Flight Manual Supplement

BGA 2007/01-02/2992 issue 1

Registration	BGA Number	Manufacturer and type	Serial Number
G-FEVS	BGA 2992	PZL Poland Puchacz SZD50-3	B1091

**Title:** BGA Operations

**Subjects:** Extended Weight Operations  
Revised Weak Links  
Revised Launch speeds  
Revised Operational Limitations

**Reference:** BGA 2007/01 issue 1 (as applicable)  
BGA 2007/02 issue 1 (as applicable)  
BGA Data Sheets

**Applicability:** Sailplanes and Self Sustaining Sailplanes issued with a BGA Certificate of Airworthiness prior to 28 September 2008 and transitioned to EASA C of A.

**Conditions:** The above aircraft, subject to applicability, is approved for operation in accordance with the applicable BGA Data Sheet, as amended.

Any limitation revised or amended by an EASA approved Airworthiness Directive shall have precedence over this flight manual supplement.

Any aircraft operating within the BGA Extended Weight category shall be re-classified as "Utility" - Non Aerobatic, whilst within the extended weight range.

Refer to the BGA Data Sheet for revised limitations.

Approved by the EU commission as a 14(6) derogation dated 4 July 2008, to EC regulation 1592/2002 and 1702/2003 as being compliant with the requirements of Part 21 for continued use on UK registered gliders. Subject to the above applicability and conditions.

**Issued by:**  
British Gliding Association Ltd,  
Kimberley House,  
Vaughan Way  
Leicester  
LE1 4SE

10 July 2008